

MODWAY HEADBOARD





Thank you for purchasing the **MOD-5365/5366/5367/5368/5369/5370/5371/5372/5373/5374/5375/5376/5377/5378/5379/5380/5381/5382/5383/5384/5385/5386/5387/5388/5389/5390/5391/5392/5393/5394/5395/5396/5397/5398/5399/5400/5401/5402/5403/5404/5405/5406/5407/5408 HEADBOARD !**

Before you start, here is some helpful advice:

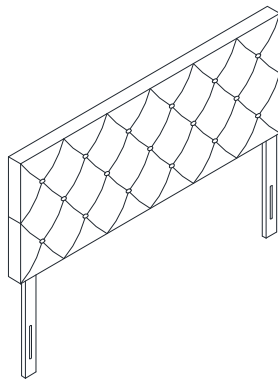
1. We suggest you spend a short time reading through this leaflet and then follow the simple step by step instructions.
2. Owing to the size and weight of the headboard, we recommend that it is assembled by two adults, on a carpeted or padded area, in the room that it is intended for. Approx assembly time: 30 minutes.
3. Please do not use any tools other than those provided or recommended in these instructions.
4. Please do not throw away any of the packaging or the instruction until you have checked all the components and hardware and the furniture is fully assembled. Please ensure that the packaging is disposed of in a safe environmentally friendly way.
5. Assemble all components loosely until advised to tighten. Depending on use, it may be necessary to tighten the components from time to time, so please save the tools that has been provided.
6. Please keep all fitting out of reach of children.



Hardware:

A		Bolt M8x45mm	x4
B		Flat Washer M8xD22mm	x4
C		Allen Wrench M5	x1

Component:

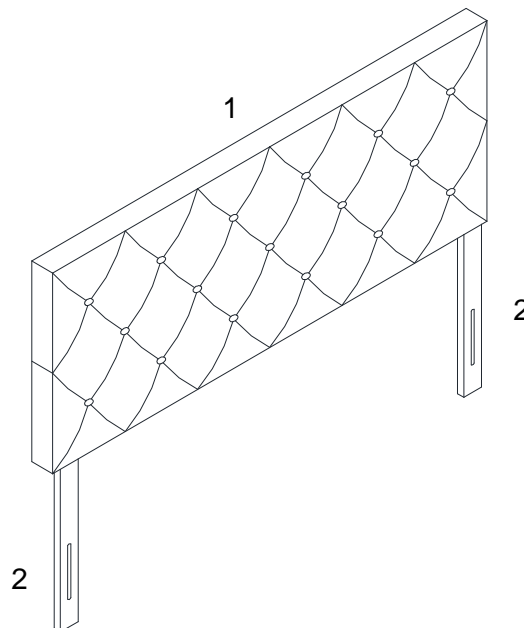

1 Headboard x1
(Style may vary)

2 Low Post x2



STEP 1:

Put the **Headboard (1)** upside down on a carpeted or padded area by two adults

Then insert the **Low Posts (2)** into the bottom of **Headboard (1)** and align pre-drilled **Low Post (2)** holes to the pre-drilled **Headboard (1)** Holes according to your desired headboard height.

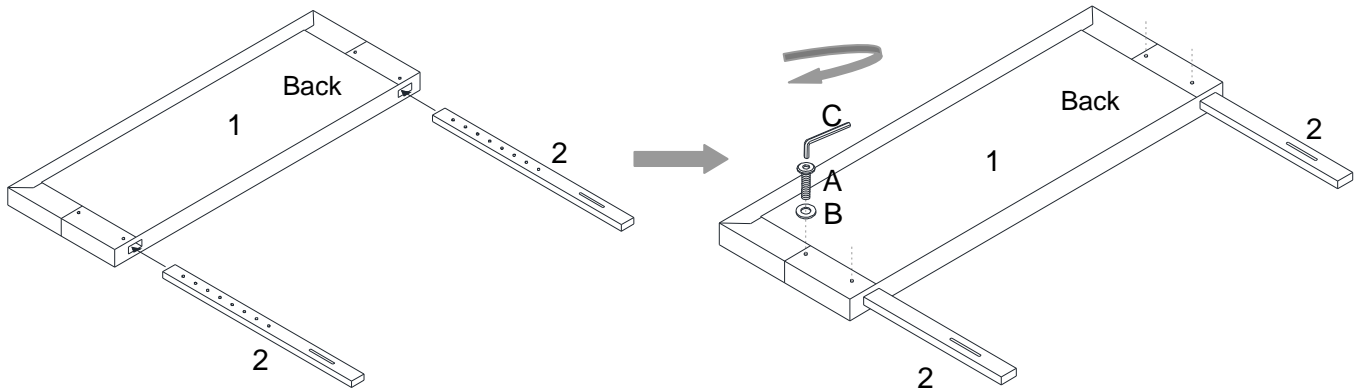
Attach each of **Low Post (2)** by using 2 piece of **Flat Washer (B)** and 2 pieces of **Bolt (A)** from the holes on the back of **Low Post (2)** and **Headboard (1)**. Tighten with **Allen Wrench (C)**.



		
Ax4	Bx4	Cx1

Hardware & Tool required

STEP 2:

Carefully turn up the assembled **Headboard (1)** by two adults.

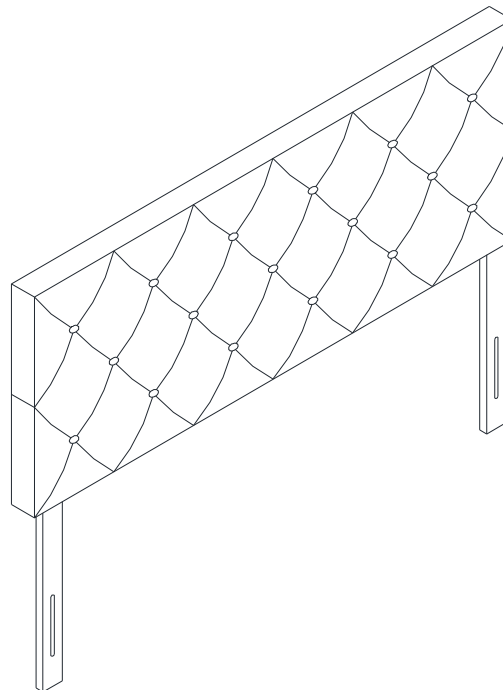

Assembly is completed. The headboard is ready to use now!





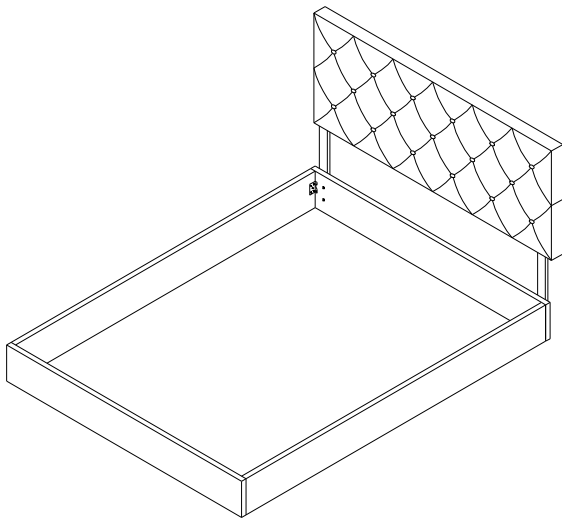

NOTE: Hardware may loosen over time. Periodically check that all connections are tight.

ASSEMBLY INSTRUCTIONS
OPTION 1

OPTION 1



Hardware:

A		Bolt M6x45mm	x4
B		Bolt M6x65mm	x4
C		Flat Washer M6xD22mm	x8
D		Spring Washer M6	x4
E		Hex Nut M6	x4
F		Allen Wrench M4	x1

Component:

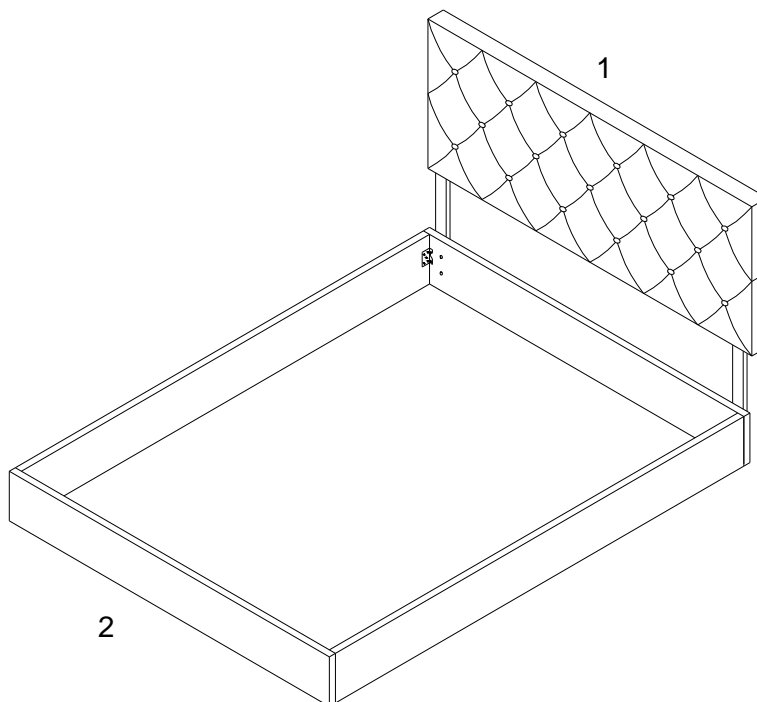

OPTION 1

1 Headboard x1
(Style may vary)

2 Bed Frame x1

Note: Extra hardware were provided for attaching the headboard to your Bed Frame (use is optional).

STEP 1:

Line up the **Bed Frame (2)** board's pre-drilled holes to match those of the **Headboard (1)**.

Secure the **Headboard (1)** to the **Bed Frame (2)** by using 2 pieces of **Bolt (B)** for the thicker **Bed Frame (2)**, and 2 pieces of **Bolt (A)** for the thinner **Bed Frame (2)**.

Before inserting each bolt, place 1 piece of **Spring Washer (D)** and **Flat Washer (C)** on each bolt. Then fit 1 piece of **Flat Washer (C)** on the bolt as it protrudes through the other side of the **Bed Frame (2)**.

Place 1 piece of **Hex Nut (E)** after the **Flat Washer (C)** at the end of each bolt. Then tighten the **Bolts (A or B)** by using the **Allen Wrench (F)**.

Repeat the same procedure for each bolt and each side of the **Bed Frame (2)**.

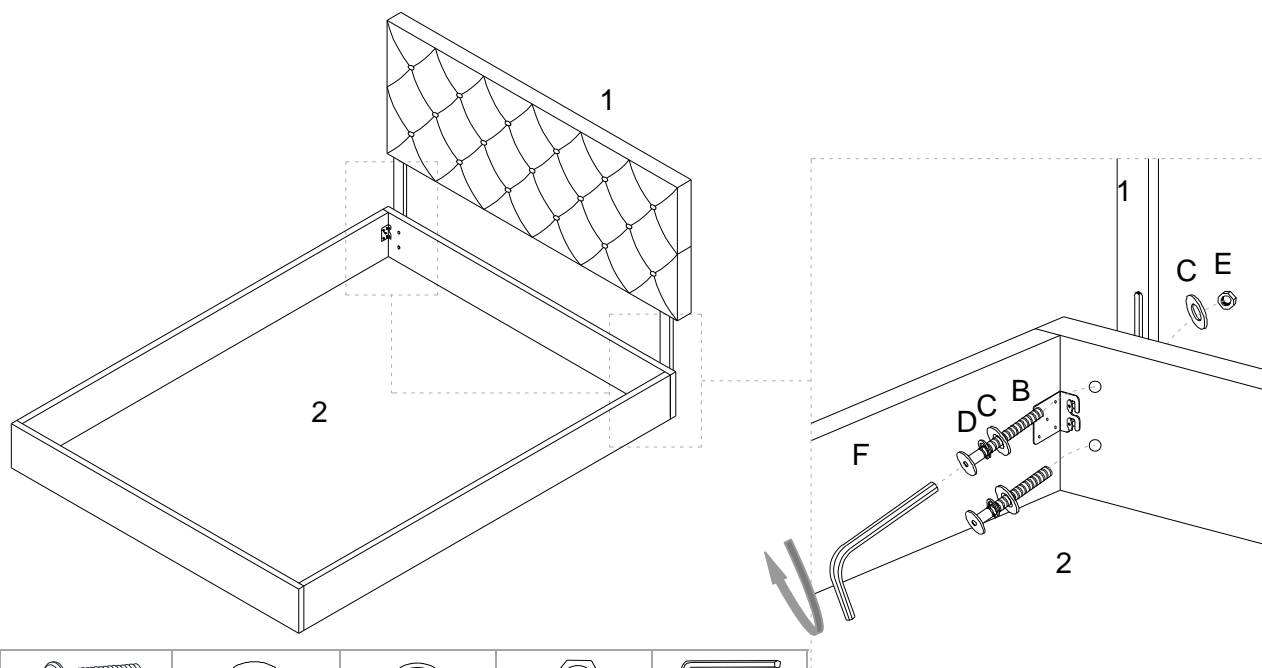

				
A or Bx4	Cx8	Dx4	Ex4	Fx1

Hardware & Tool required

STEP 2:

Carefully position the assembled bed to the desired location by four adults.

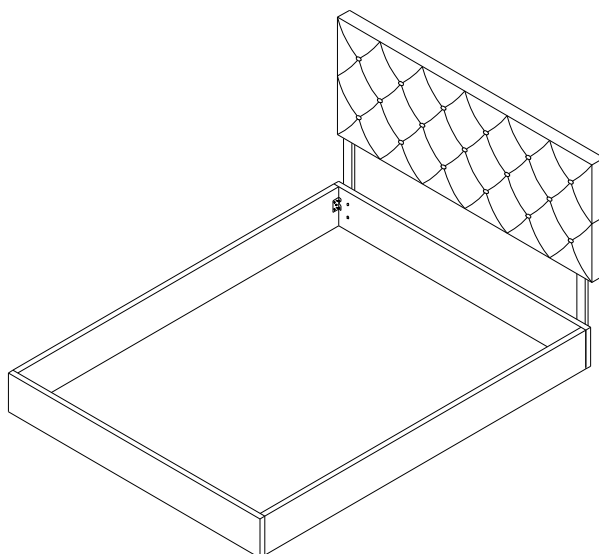

Assembly is completed. The bed is ready to use now!

NOTE: Hardware may loosen over time. Periodically check that all connections are tight.

ASSEMBLY INSTRUCTIONS



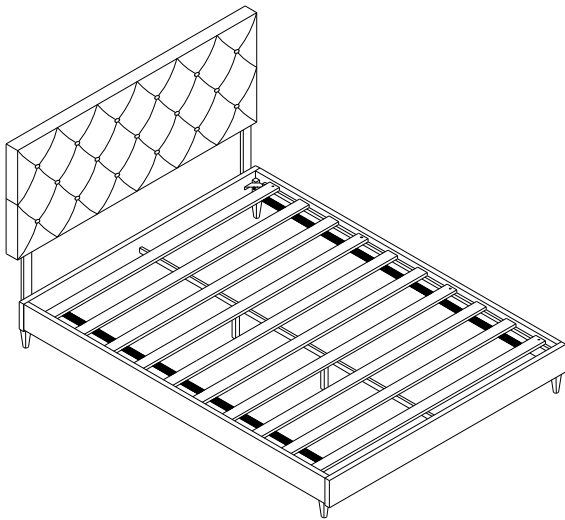

OPTION 2

Note: This is assembly instruction for Headboard connect to MODWAY Bed Frame **MOD-5347/5348/5349/5350/5351/5352/5353/5354/5357/5358/5359/5360/5361/5362/5363/5364.**

OPTION 2



Hardware:

A		Bolt M6x45mm	x4
B		Bolt M6x65mm	x4
C		Flat Washer M6xD22mm	x4
D		Spring Washer M6	x4
F		Allen Wrench M4	x1

Component:

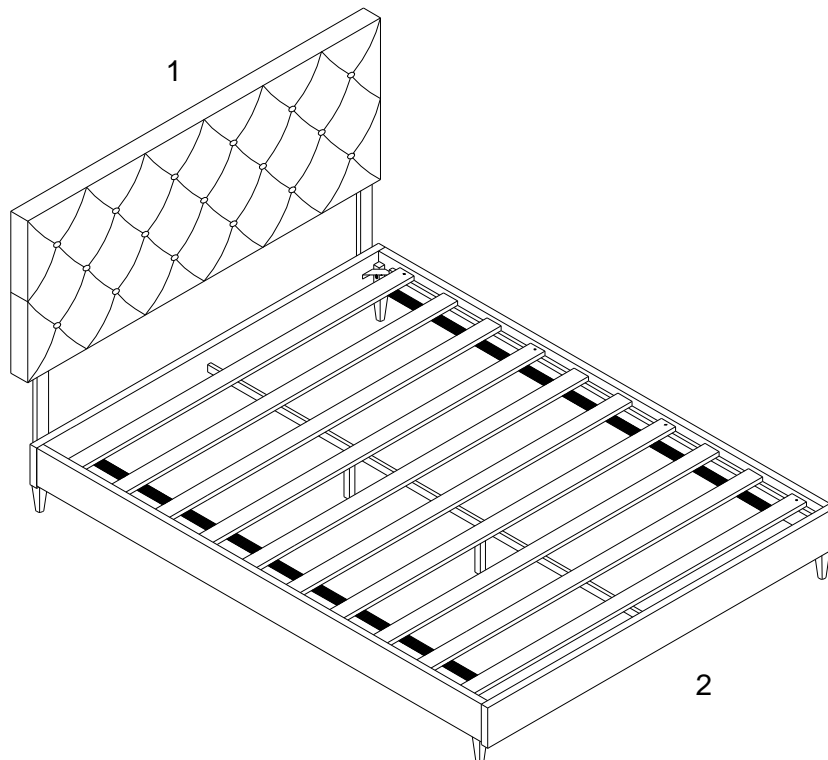

OPTION 2

1 Headboard x1
(Style may vary)

2 Bed Frame x1
(Style may vary)

STEP 1:





Line up the **Bed Frame (2)** board's pre-drilled holes to match those of the **Headboard (1)**.

Secure the **Headboard (1)** to the **Bed Frame (2)** by using 2 pieces of **Bolt (B)** with 2 pieces of **Spring Washer (D)**, 2 pieces of **Flat Washer (C)** for the thicker **Bed Frame (2)**, and 2 pieces of **Bolt (A)** with 2 pieces of **Spring Washer (D)**, 2 pieces of **Flat Washer (C)** for the thinner **Bed Frame (2)**.

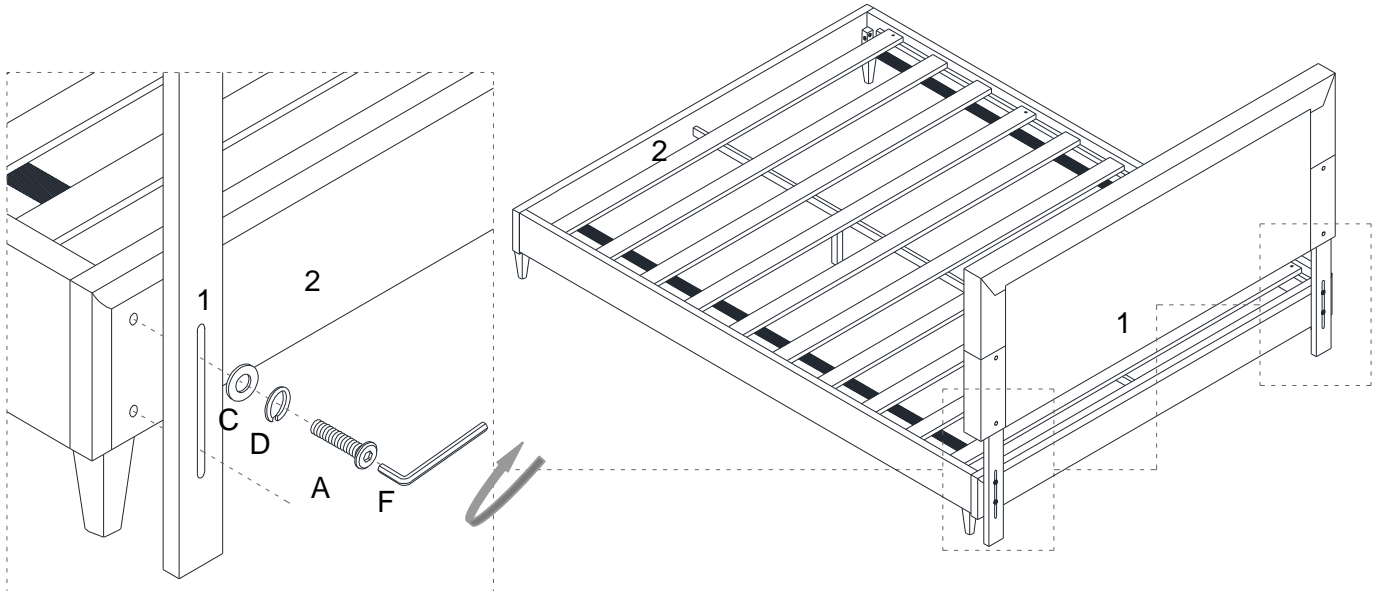
Then tighten the **Bolts (A or B)** by using the **Allen Wrench (F)**.

Repeat the same procedure for each bolt and each side of the **Bed Frame (2)**.



			
A or Bx4	Cx4	Dx4	Fx1

Hardware & Tool required

STEP 2:

Carefully position the assembled bed to the desired location by four adults.

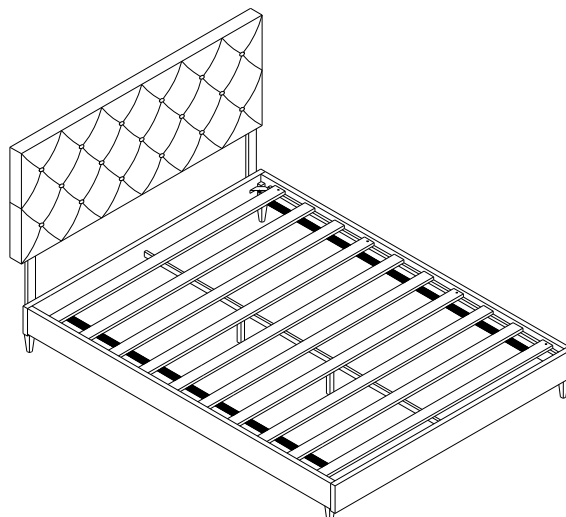

Assembly is completed. The bed is ready to use now!

NOTE: Hardware may loosen over time. Periodically check that all connections are tight.