

ASSEMBLY INSTRUCTIONS

MOD-7083

V0.02.02.23

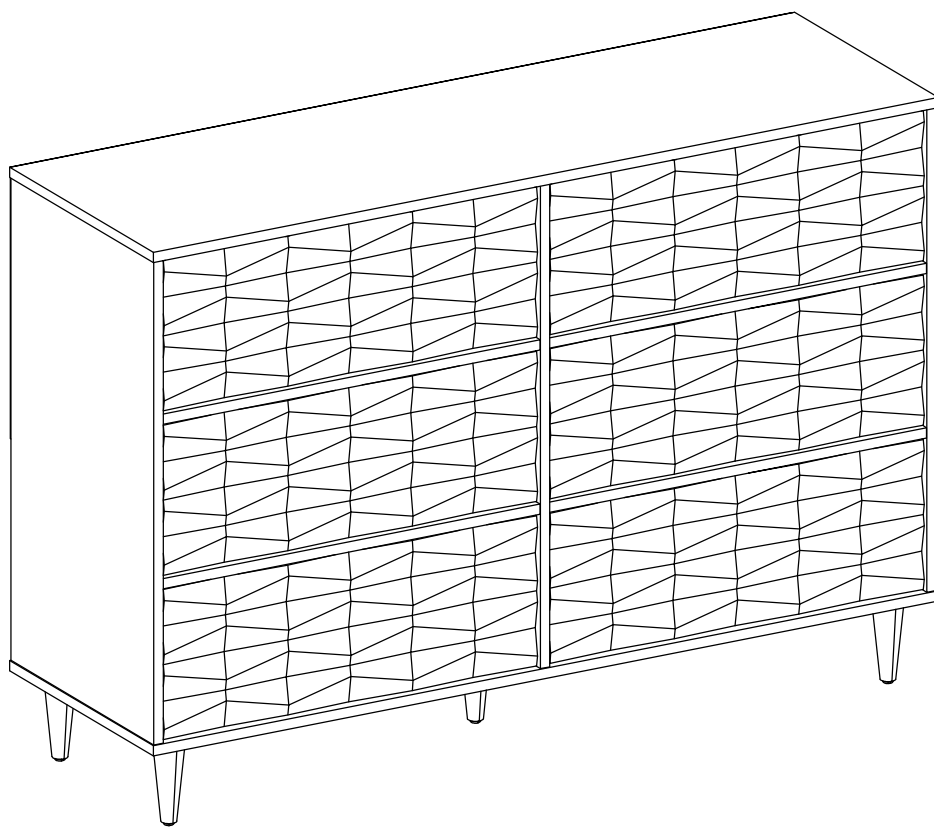

Questions? Contact us!

609.256.9000 • cs@modway.com
www.modway.com

*modway

Let's get started!

***modway**



Read through all of the instructions before starting



Care instructions are listed in the last step of this manual



Approx. 60 minutes assembly time



Make sure you have all parts and components before discarding any packing materials



2 people recommended for assembly

Only use hand tools to assemble this item. Do not use power tools. Do not tighten bolts or screws completely until all hardware is lined up and inserted into the holes.

Do not over-tighten screws and bolts to avoid stripping the hardware or cracking the item.

Assemble your item on a flat, carpeted area, with plenty of space to work. This will prevent damage and scratches to your floors or the item while you're assembling the product.

Keep all components and packaging out of reach of children or animals to avoid risk of choking or suffocation.

Furniture components:

1	Top Board	x1
2	Bottom Board	x1
3	Left Side Board	x1
4	Right Side Board	x1
5	Divider Board	x1
6	Drawer Support	x4
7	Rear Board	x2
8	Side Leg	x4
9	Middle Leg	x1
10	Front Drawer Board	x6
11	Rear Drawer Board	x6
12	Left Side Drawer Board	x6
13	Right Side Drawer Board	x6
14	Support Drawer Board	x6
15	Bottom Drawer Board	x6

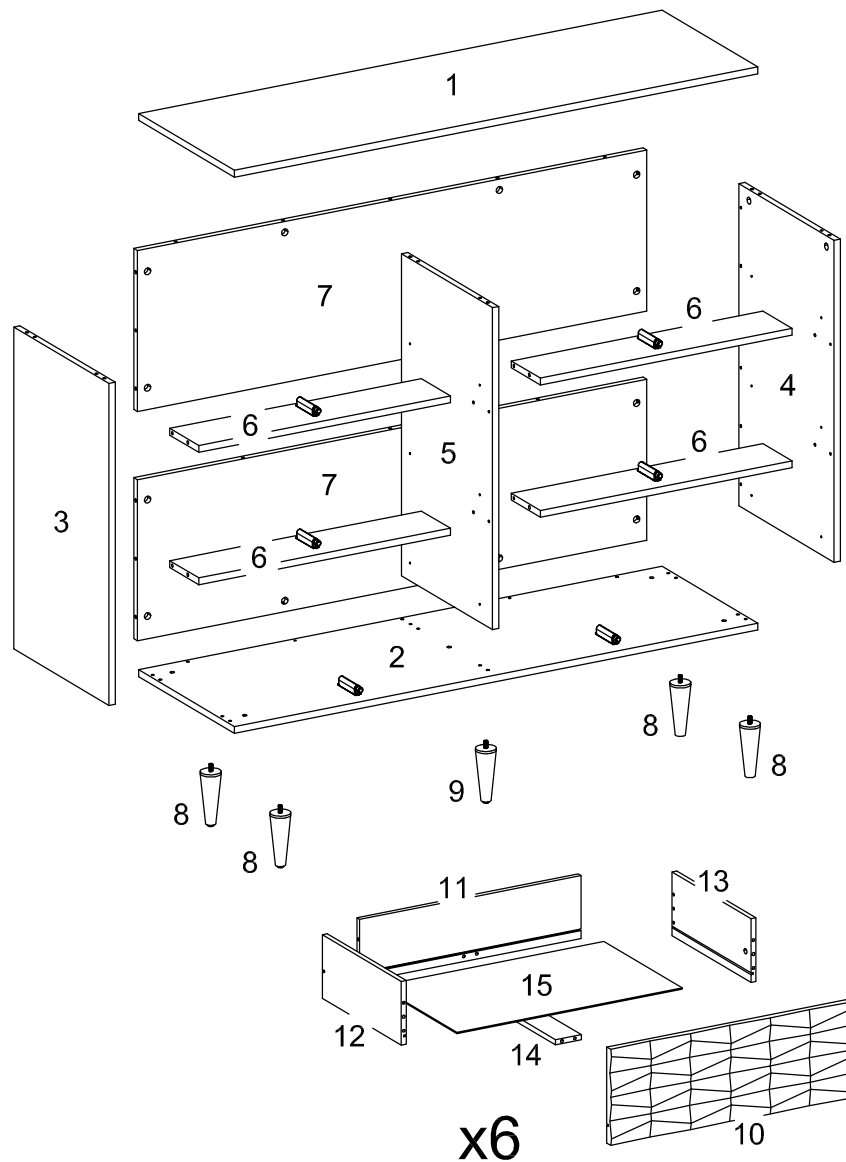

















Wait!

Missing parts or hardware? Need assistance?

Contact us before returning your item. We're here to help!

609.256.9000 • cs@modway.com

Provided hardware:

A		Cam Lock Ø15 mm	x26
B		Cam Bolt Ø7.5 x 32 mm	x44
C		Cam Cover Ø17 mm	x26
D		Plastic Dowel Ø6 x 30 mm	x93
E		Screw M 6 x 8 mm	x36
F		Screw M 6 x 13 mm	x24
G		Screw M 10 x 33.5 mm	x24
H		Sleeve Nut	x5
I		Allen Key	x1
J		Push TO Open	x6
K		Cam Lock Ø12 mm	x18
L		Drawer Rails	x6
M		Wall Bracket Set	x1
N		Cam Cover Ø12 mm	x12
O		Backply Stopper	x24
P		Screw M 4 x 19 mm	x24
Q		Screw M 6 x 9 mm	x12

What you need:

 Phillips Head Screwdriver

Wait!

Missing parts or hardware? Need assistance?

Contact us before returning your item. We're here to help!

609.256.9000 • cs@modway.com

Step 1

HARDWARE

B Cam Bolt $\varnothing 7.5 \times 32$ mm x8

COMPONENTS

1 Top Board x1

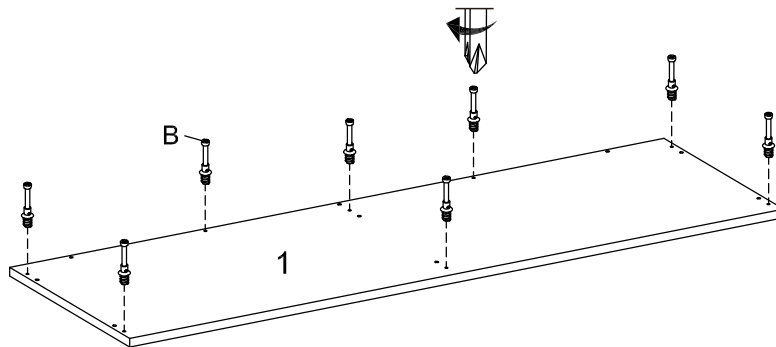

Step 2

HARDWARE

B Cam Bolt $\varnothing 7.5 \times 32$ mm x2

E Screw M 6 x 8 mm x4

J Push To Open x2

COMPONENTS

2 Bottom Board x1

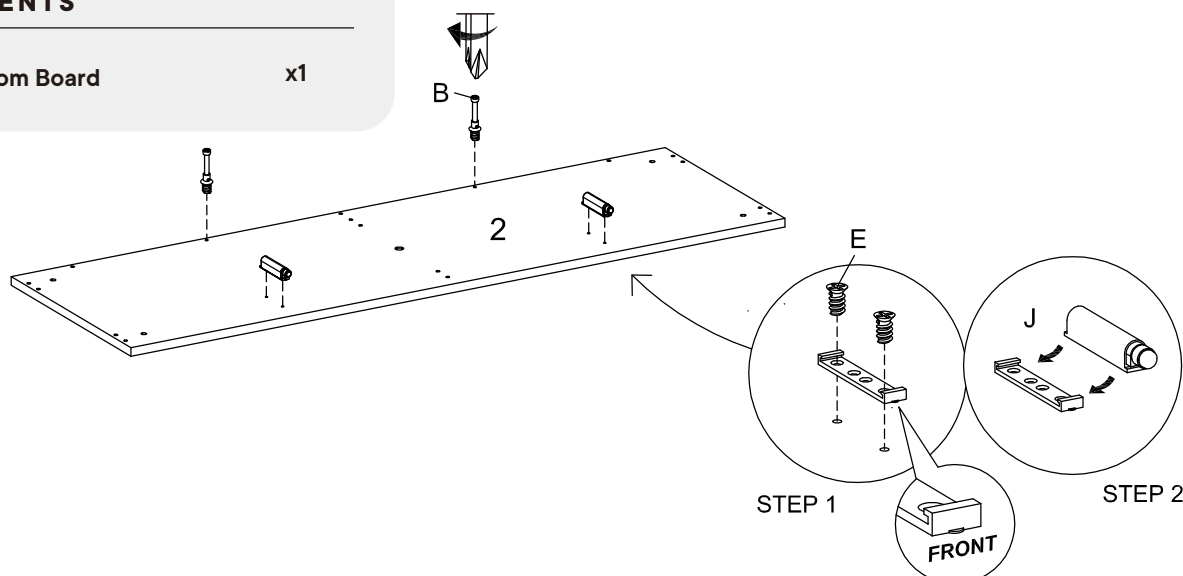

Step 3

HARDWARE

B	Cam Bolt $\varnothing 7.5 \times 32$ mm	x6
D	Plastic Dowel $\varnothing 6 \times 30$ mm	x4
E	Screw M 6 x 8 mm	x6
L	Drawer Rail (Left)	x3
Q	Screw M 6 x 9 mm	x3

COMPONENTS

3	Left Side Board	x1
----------	-----------------	----

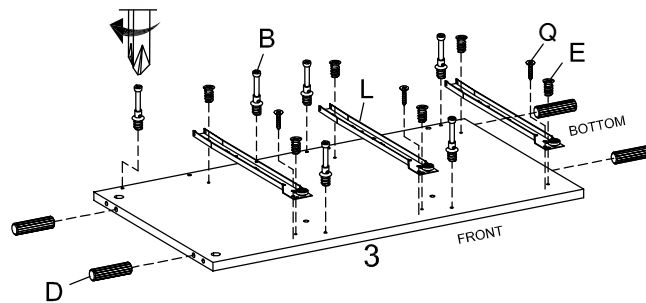
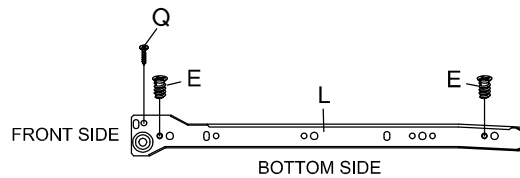

Step 4

HARDWARE

B	Cam Bolt $\varnothing 7.5 \times 32$ mm	x6
D	Plastic Dowel $\varnothing 6 \times 30$ mm	x4
E	Screw M 6 x 8 mm	x6
L	Drawer Rail (Right)	x3
Q	Screw M 6 x 9 mm	x3

COMPONENTS

4	Right Side Board	x1
----------	------------------	----

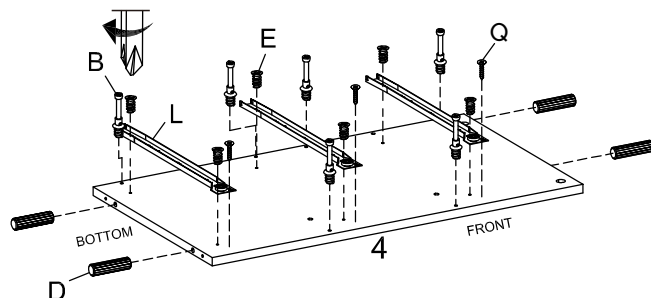
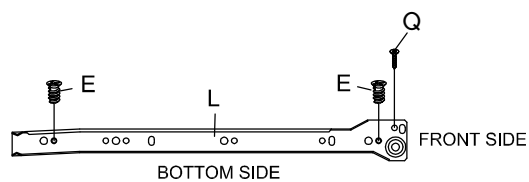

Step 5

HARDWARE

- B** Cam Bolt $\varnothing 7.5 \times 32$ mm x4
- D** Plastic Dowel $\varnothing 6 \times 30$ mm x4
- E** Screw M 6 x 8 mm x12
- L** Drawer Rail x3
- Q** Screw M 6 x 9 mm x6

COMPONENTS

- 9** Divider Board x1

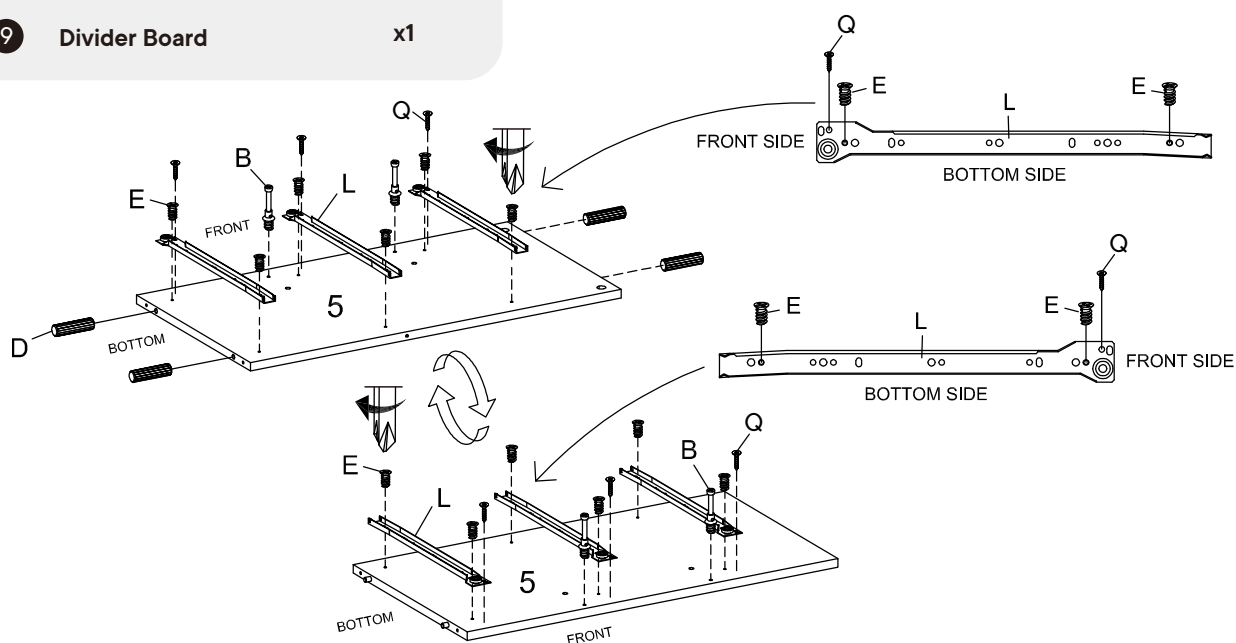

Step 6

HARDWARE

- D** Plastic Dowel $\varnothing 6 \times 30$ mm x10

COMPONENTS

- 7** Rear Board x2

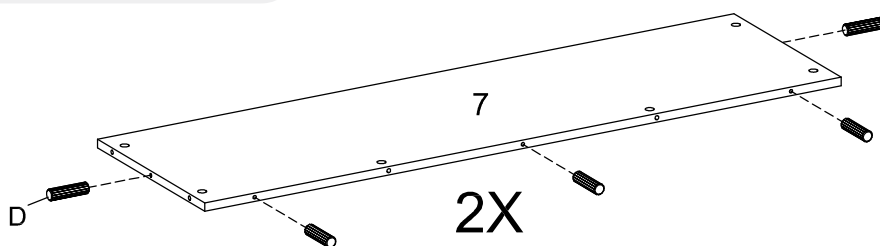

Step 7

HARDWARE

- D** Plastic Dowel Ø6 x 30 mm x8
- E** Screw M 6 x 8 mm x8
- J** Push To Open x4

COMPONENTS

- 6** Drawer Support x4

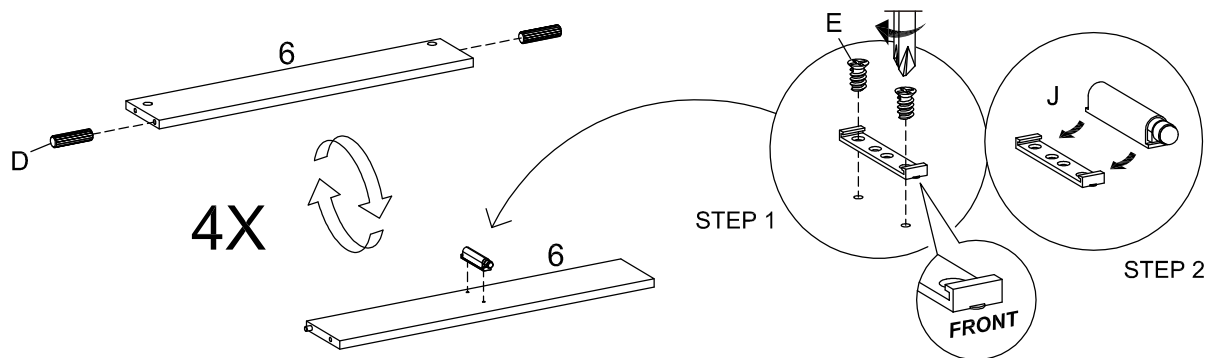

Step 8

HARDWARE

- D** Plastic Dowel Ø6 x 30 mm x3

COMPONENTS

- 7** Rear Board x2

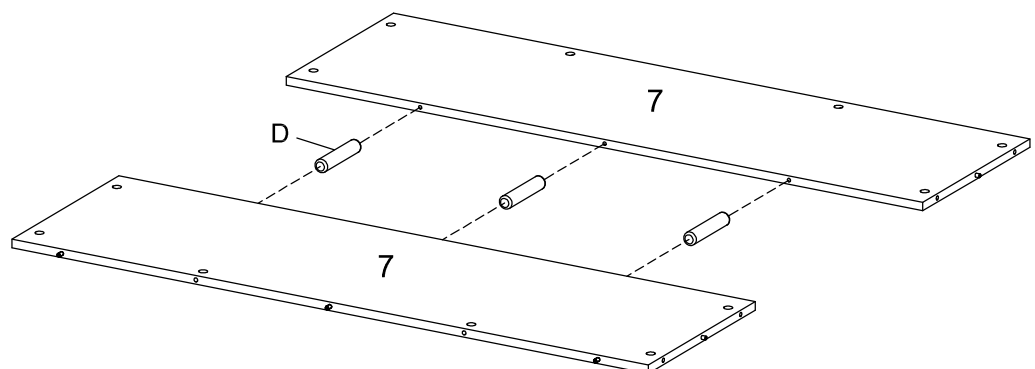

Step 9

HARDWARE

- A** Cam Lock Ø15 mm x4
- C** Cam Cover Ø17 mm x4

COMPONENTS

- 3** Left Side Board x1
- 7** Rear Board x2

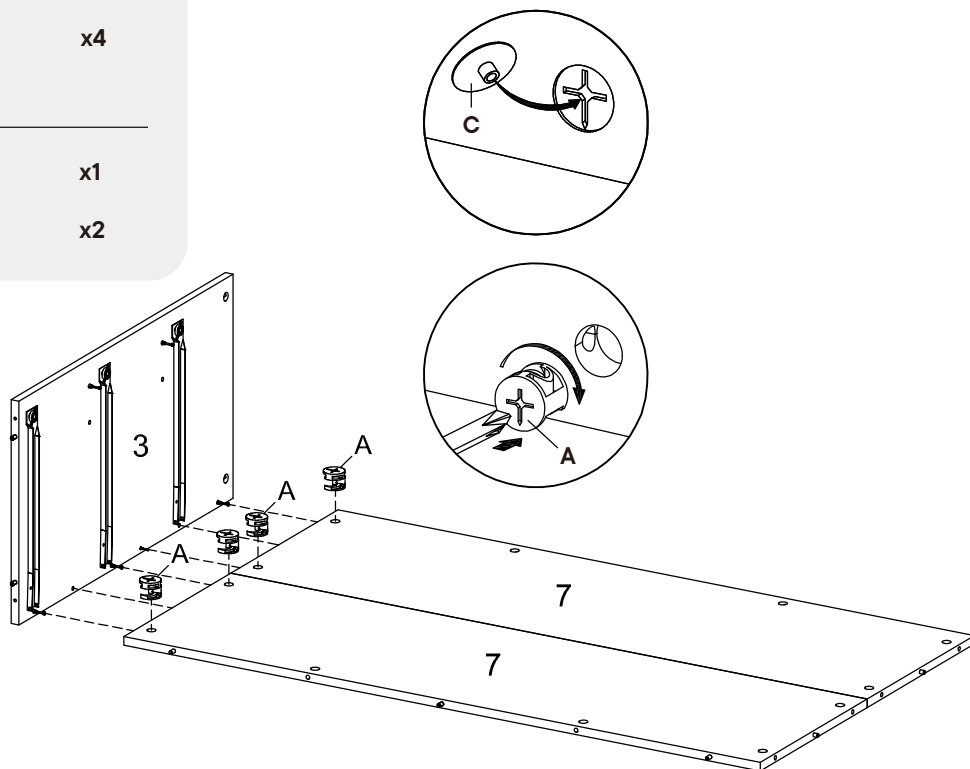

Step 10

HARDWARE

- A** Cam Lock Ø15 mm x2
- C** Cam Cover Ø17 mm x2

COMPONENTS

- 3** Left Side Board x1
- 6** Drawer Support x2

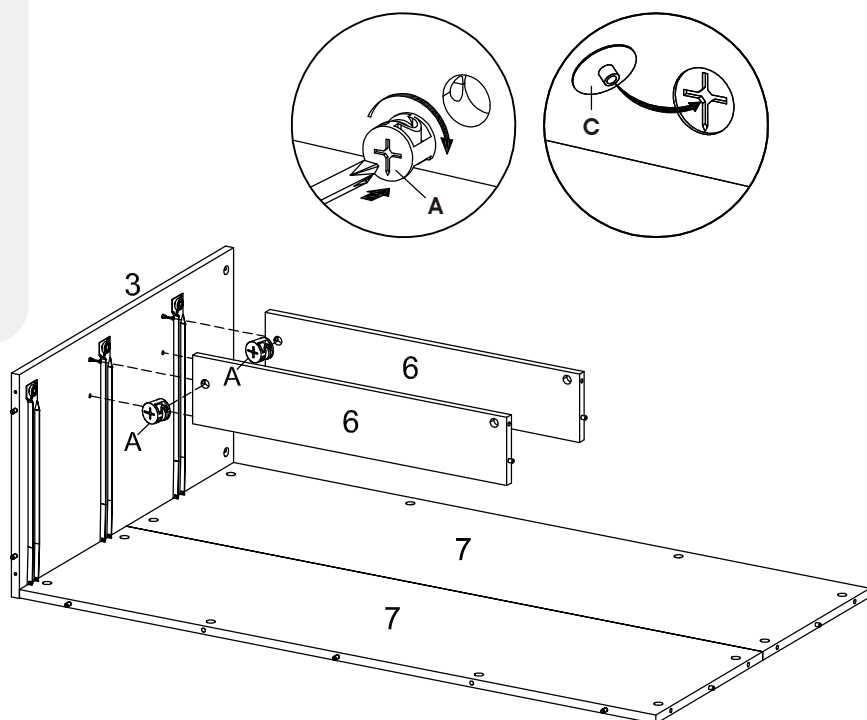

Step 11

HARDWARE

- A** Cam Lock Ø15 mm x2
- C** Cam Cover Ø17 mm x2

COMPONENTS

- 5** Divider Board x1
- 6** Drawer Support x2

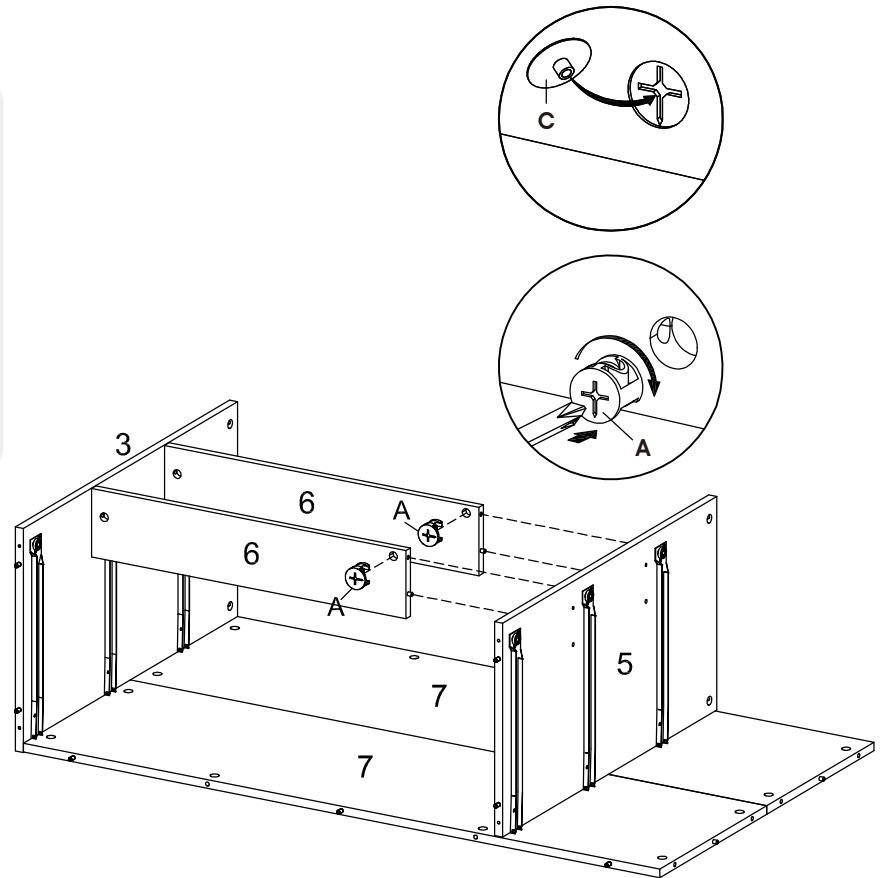

Step 12

HARDWARE

- A** Cam Lock Ø15 mm x2
- C** Cam Cover Ø17 mm x2

COMPONENTS

- 5** Divider Board x1
- 6** Drawer Support x2

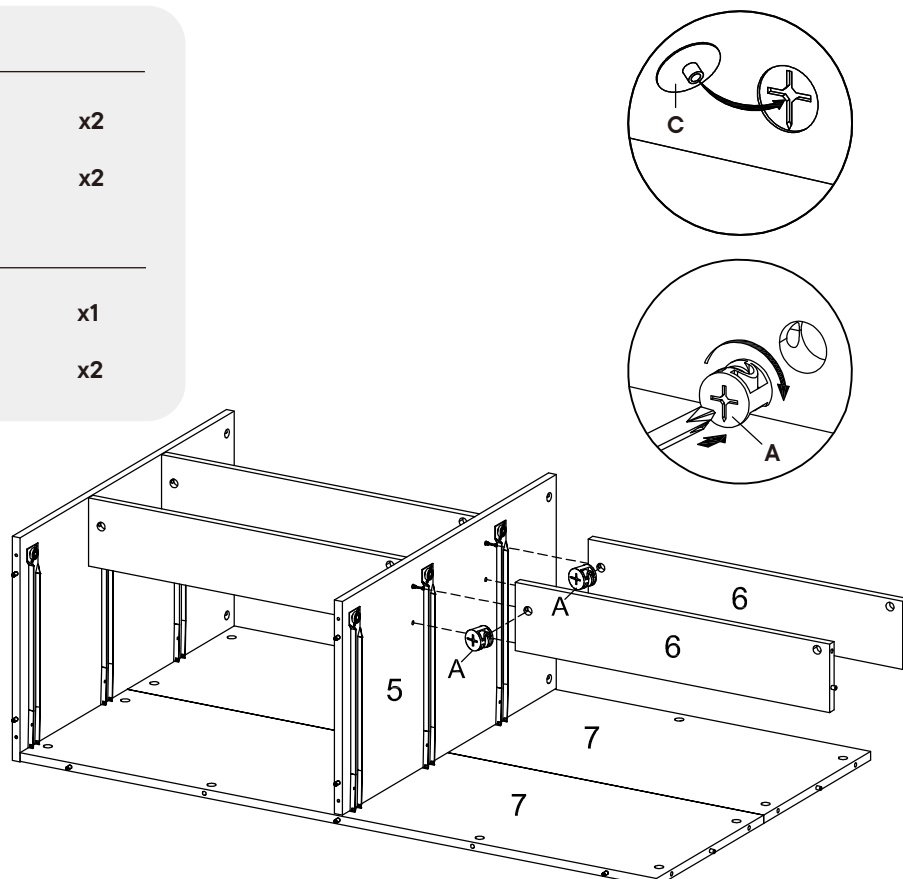

Step 13

HARDWARE

- | | | |
|----------|------------------|----|
| A | Cam Lock Ø15 mm | x6 |
| C | Cam Cover Ø17 mm | x6 |

COMPONENTS

- | | | |
|----------|------------------|----|
| 4 | Right Side Board | x1 |
| 6 | Drawer Support | x2 |
| 7 | Rear Board | x2 |

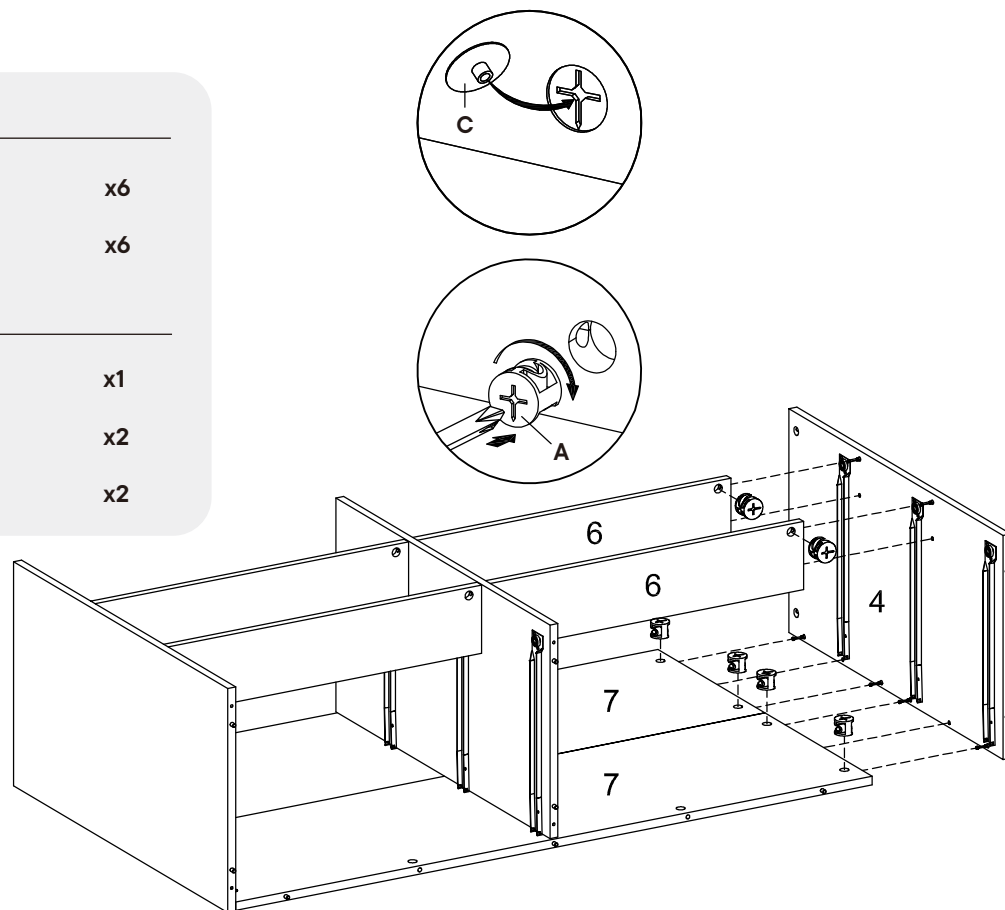

Step 14

HARDWARE

- | | | |
|----------|------------|----|
| H | Sleeve Nut | x5 |
| I | Allen Key | x1 |

COMPONENTS

- | | | |
|----------|--------------|----|
| 2 | Bottom Board | x1 |
| 8 | Legs | x4 |
| 9 | Middle Leg | x1 |

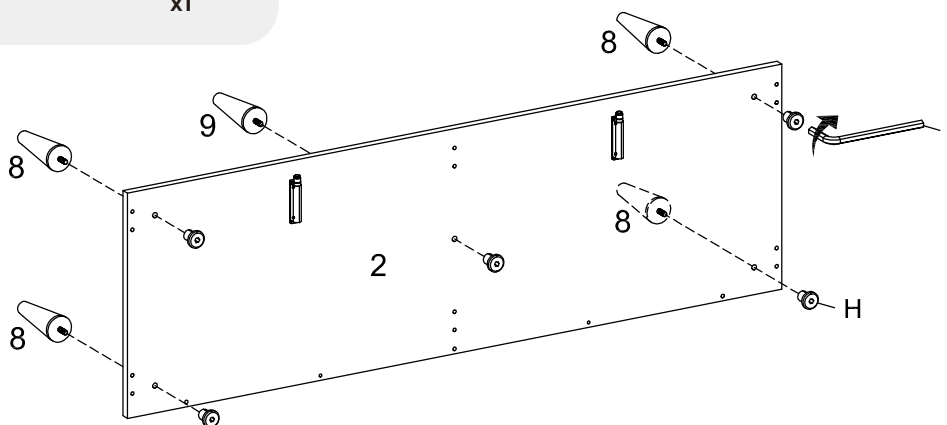

Step 15

HARDWARE

A	Cam Lock Ø15 mm	x2
C	Cam Cover Ø17 mm	x2
G	Screw M 10 x 33.5 mm	x6

COMPONENTS

2	Bottom Board	x1
3	Left Side Board	x1
4	Right Side Board	x1
5	Divider Board	x1
7	Rear Board	x1

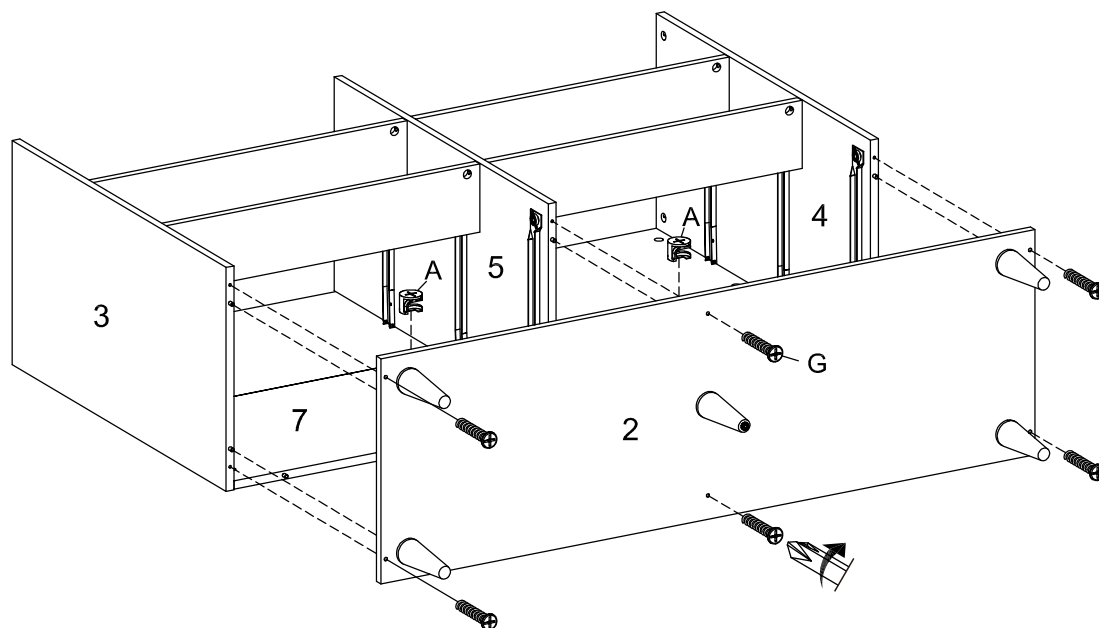

Step 16

HARDWARE

- | | | |
|----------|------------------|----|
| A | Cam Lock Ø15 mm | x8 |
| C | Cam Cover Ø17 mm | x8 |

COMPONENTS

- | | | |
|----------|------------------|----|
| 1 | Top Board | x1 |
| 3 | Left Side Board | x1 |
| 4 | Right Side Board | x1 |
| 5 | Divider Board | x1 |
| 7 | Rear Board | x1 |

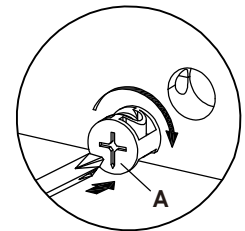
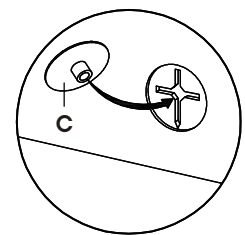
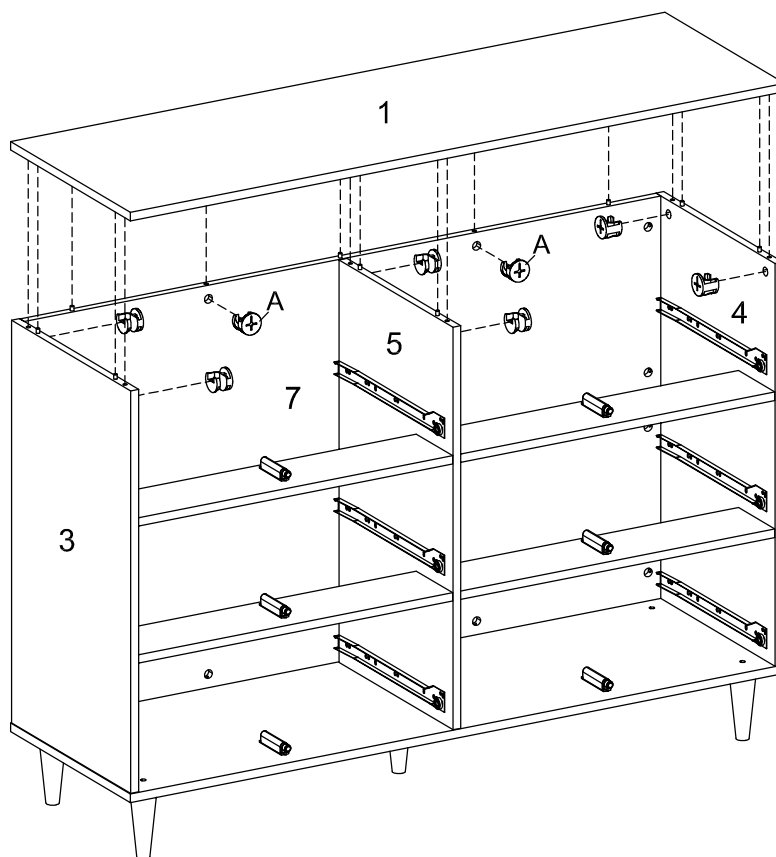

Step 17

HARDWARE

- B** Cam Bolt $\varnothing 7.5 \times 32$ mm x18
- D** Plastic Dowel $\varnothing 6 \times 30$ mm x60

COMPONENTS

- 10** Front Drawer Board x6
- 11** Rear Drawer Board x6
- 12** Left Drawer Board x6
- 13** Right Drawer Board x6
- 14** Support Drawer Board x6

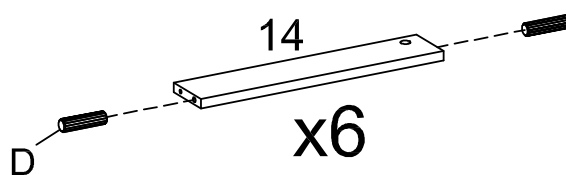
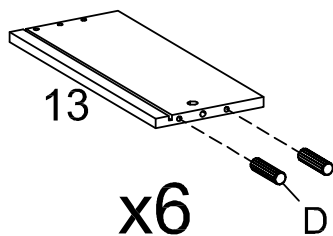
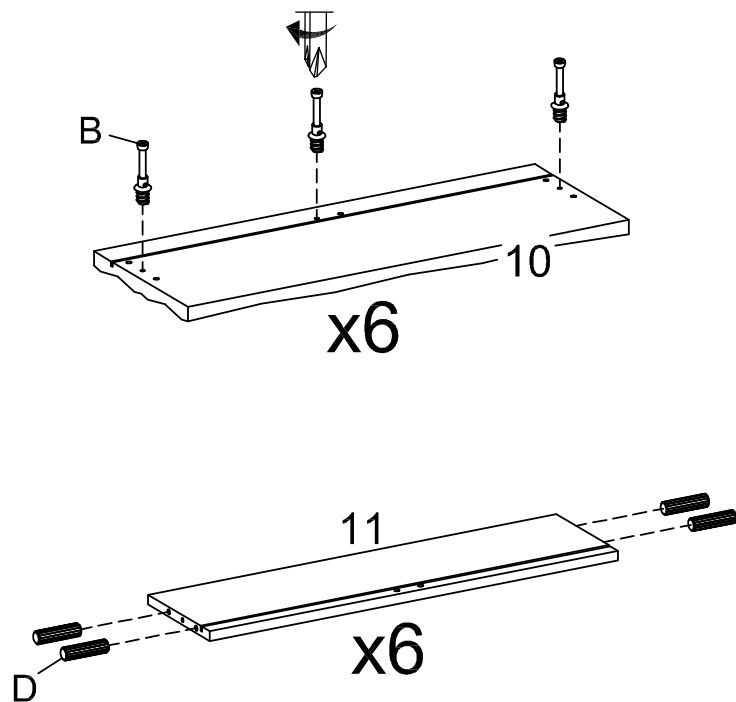
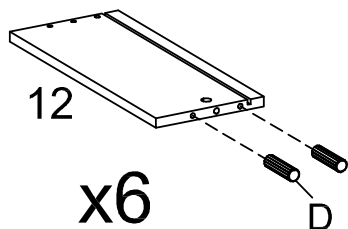

Step 18

HARDWARE

- G** Screw M 10 x 33.5 mm x18

COMPONENTS

- 11** Rear Drawer Board x6
- 12** Left Drawer Board x6
- 13** Right Drawer Board x6
- 14** Support Drawer Board x6
- 15** Bottom Drawer Board x6

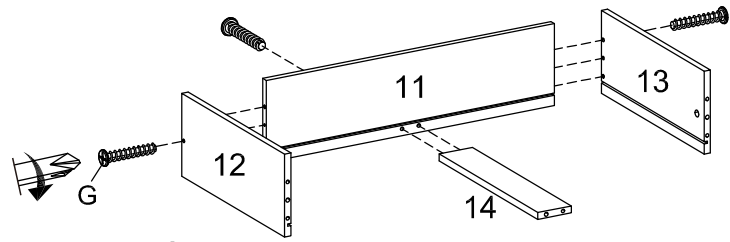

6X

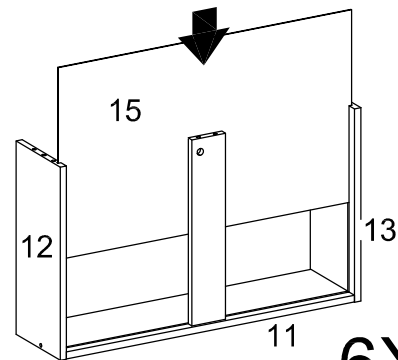

6X

Step 19

HARDWARE

- K** Cam Lock Ø12 mm x18
- N** Cam Cover Ø12 mm x12

COMPONENTS

- 10** Front Drawer Board x6
- 12** Left Drawer Board x6
- 13** Right Drawer Board x6
- 14** Support Drawer Board x6
- 15** Bottom Drawer Board x6

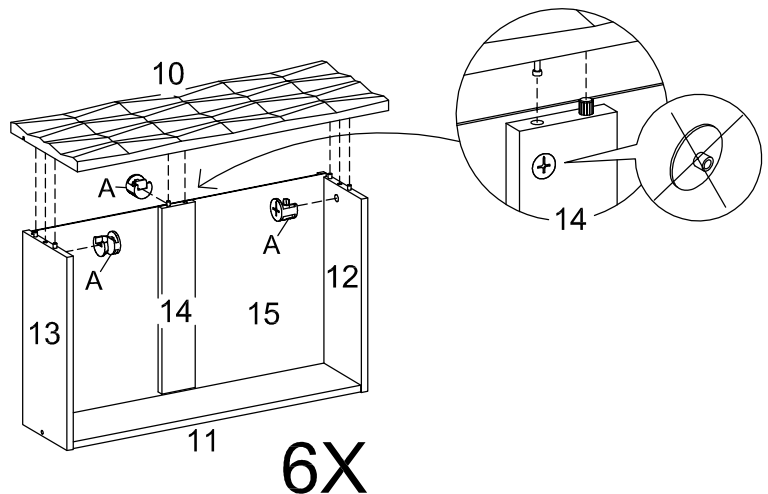
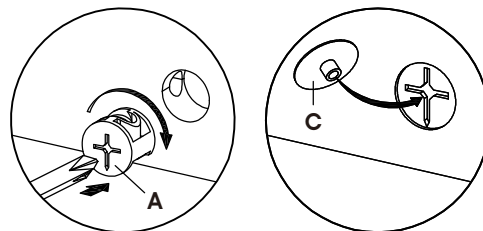

6X

Step 20

HARDWARE

- O** Backply Stopper x4
- P** Screw M 4 x 19 mm x4

COMPONENTS

- 10** Front Drawer Board x6
- 12** Left Drawer Board x6
- 13** Right Drawer Board x6
- 15** Bottom Drawer Board x6

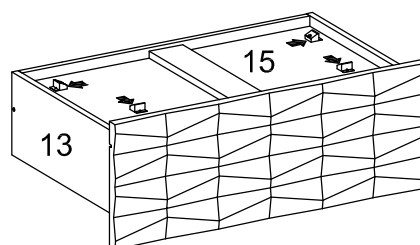
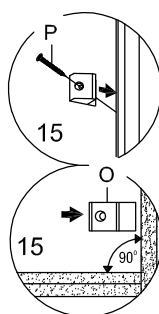
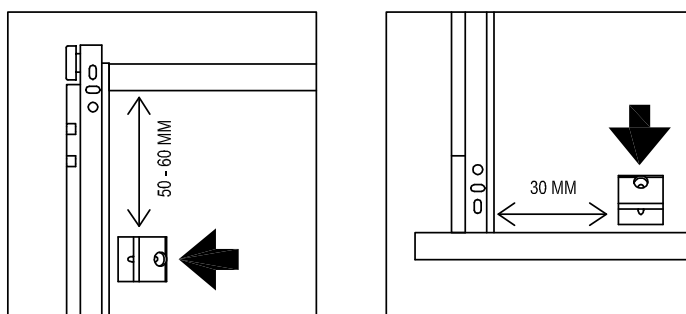

6X

Step 21

HARDWARE

- F** Screw M 6 x 13 mm x24
- L** Drawer Rails x6

COMPONENTS

- 12** Left Drawer Board x6
- 13** Right Drawer Board x6

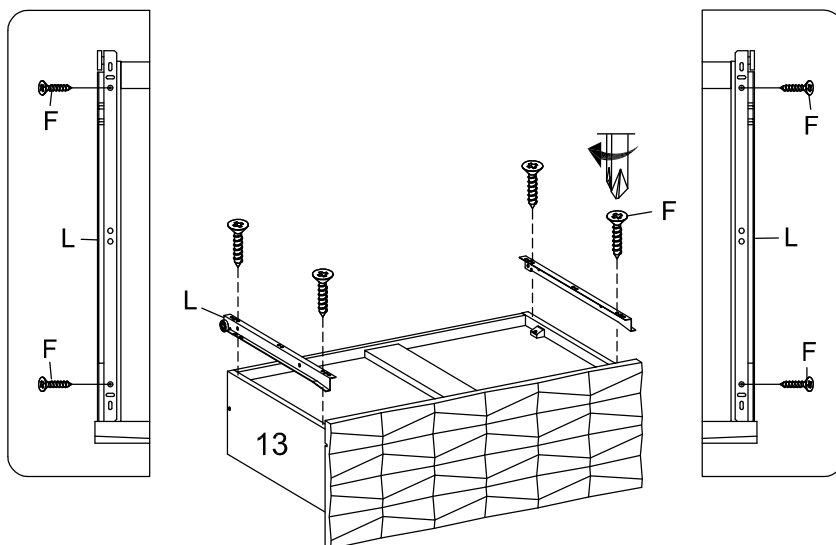

6X

Step 22

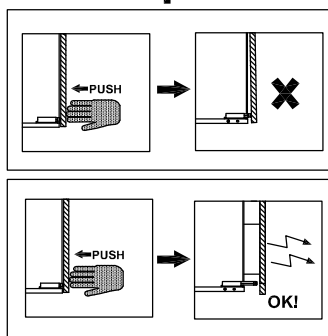
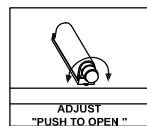
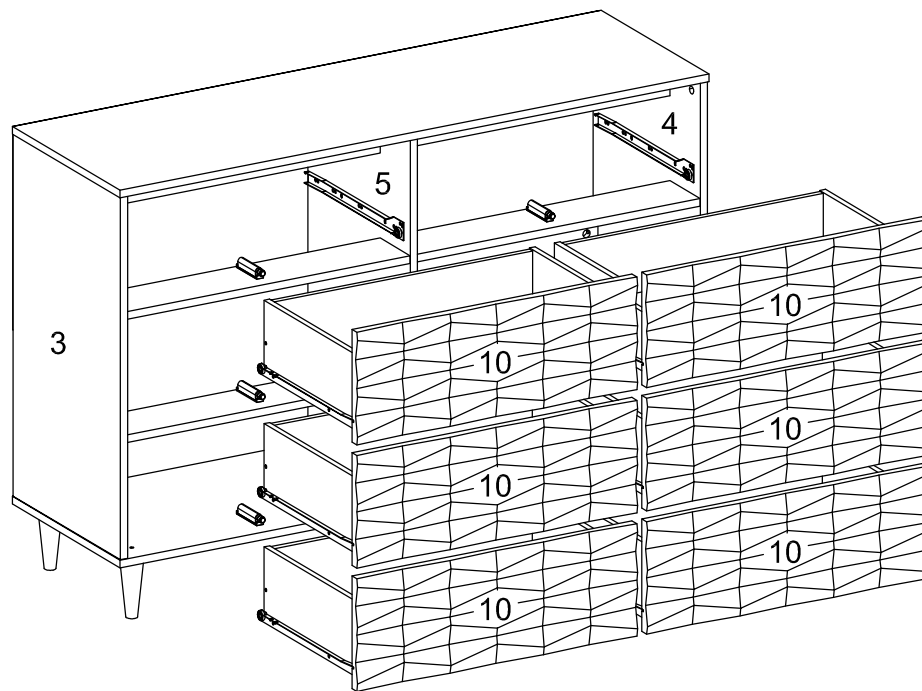

Great job!

Dresser assembly is complete.

♥ CARING FOR YOUR ITEM

Indoor use only.

Not contract grade.

Clean using a non-abrasive cloth and a mild cleaner.

Never use harsh chemicals, as they could damage the finish or integrity of the item.

CONNECT WITH US!

Tag us @modway_furniture and #modway for a chance to be featured.

Max 35Kgs

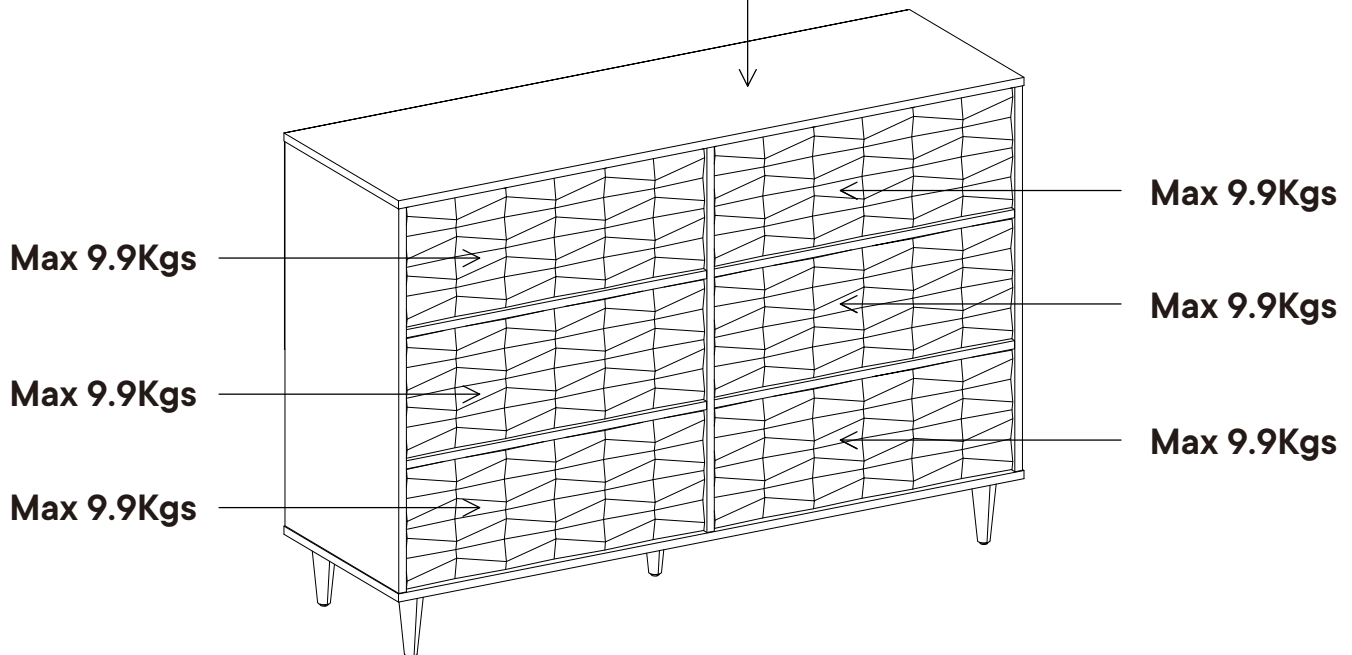

TIPPING RESTRAINTS KIT INSTALLATION GUIDANCE

Different wall materials require unique wall fasteners.

Please consult your local hardware store to ensure you are using the correct hardware for you wall type.

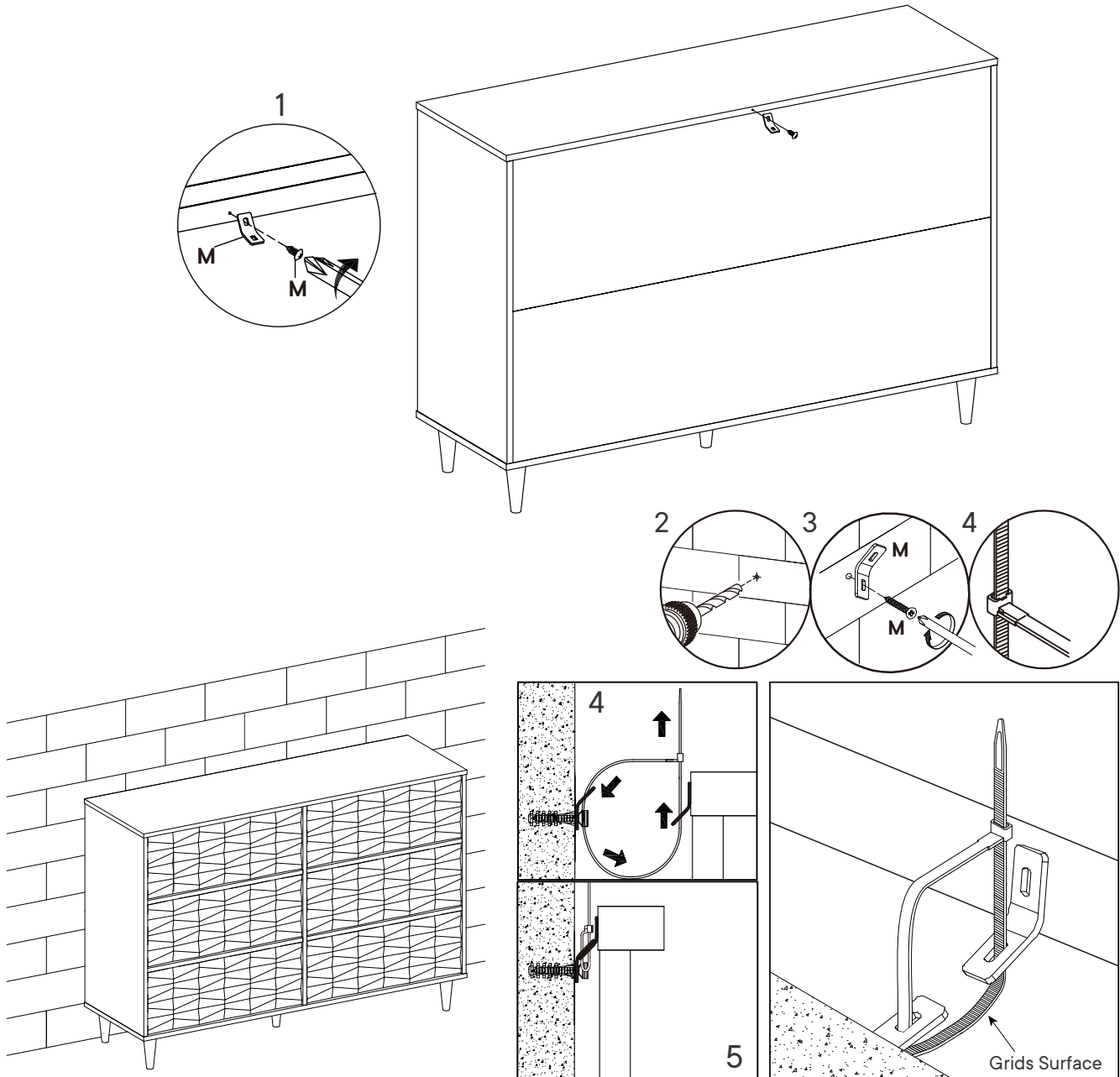
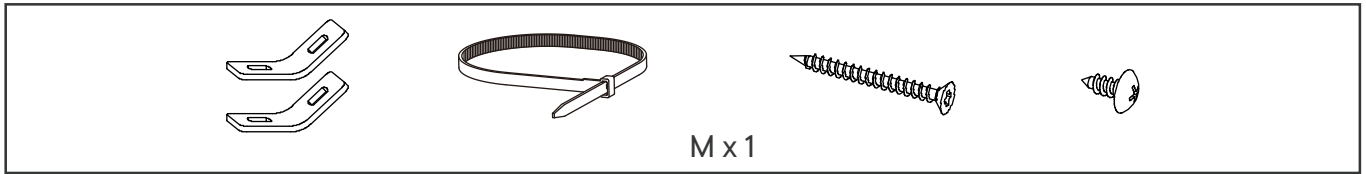

Installation Instructions :

1. Attach bracket (M) securely to the back top of the furniture using short screw (M) provided.
2. Please make a hole on the wall for attach the bracket (M) to the back of unit.
3. Attach bracket (M) on the wall using long screw (M) as shown.
Locate the other bracket (M) on the wall. Place furniture into position so both brackets (M) as shown.
4. Lace the end of the restrains strap through the larger hole in each bracket. Ensure the restrains strap with grids surface facing the inner loops. Bring both ends together and slide the flat end through the locking end and draw it through until all slack is removed.
5. Make sure that the strap is securely laced & locked.