

ASSEMBLY INSTRUCTIONS

MOD-7071

V2. 01.10.22

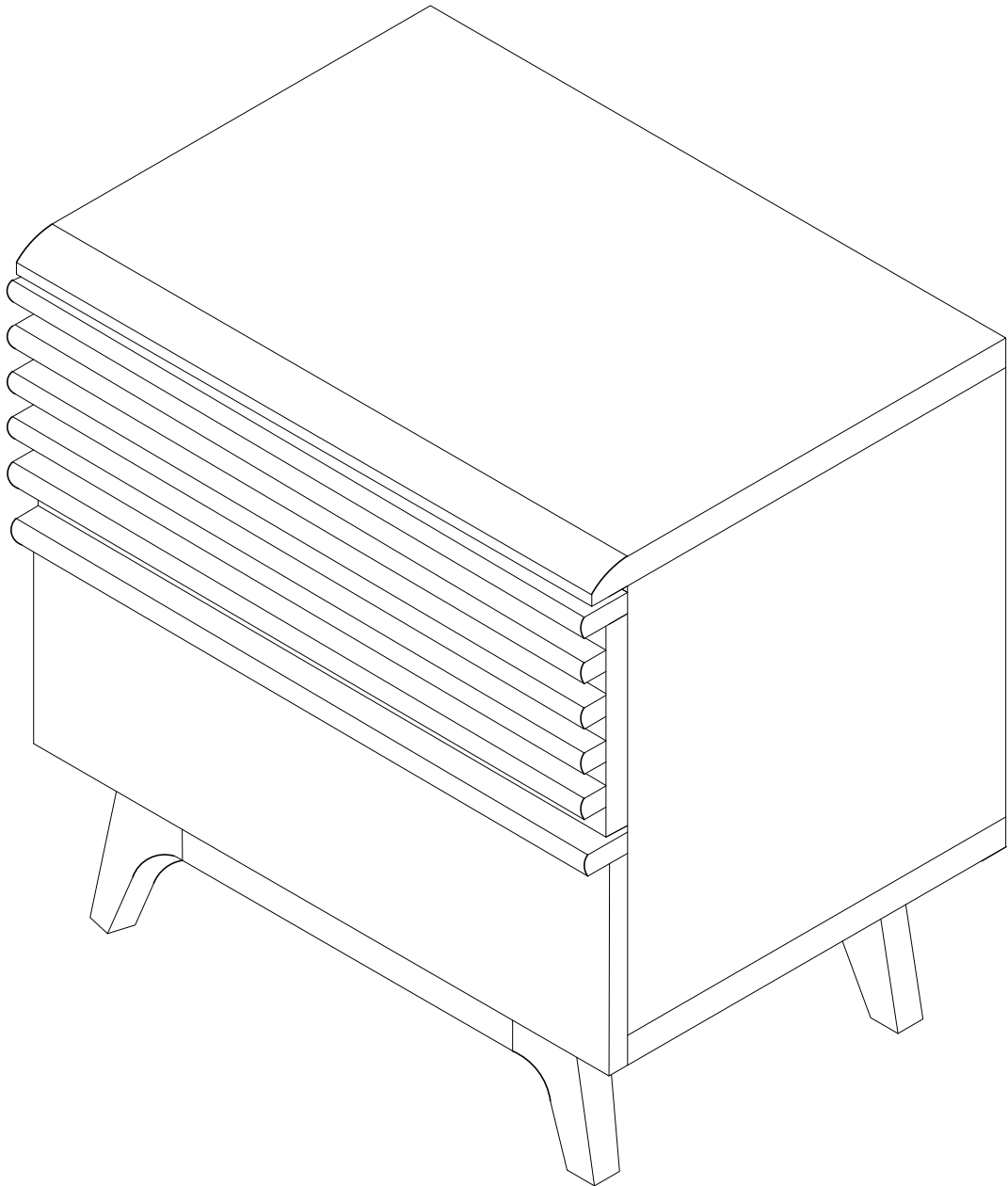

Questions? Contact us!

609.256.9000 • cs@modway.com
www.modway.com

***modway**

Let's get started!



Read through all of the instructions before starting



Care instructions are listed in the last step of this manual



Approx. 60 minutes assembly time



Make sure you have all parts and components before discarding any packing materials



2 people recommended for assembly

Only use hand tools to assemble this item. Do not use power tools. Do not tighten bolts or screws completely until all hardware is lined up and inserted into the holes.

Do not over-tighten screws and bolts to avoid stripping the hardware or cracking the item.

Assemble your item on a flat, carpeted area, with plenty of space to work. This will prevent damage and scratches to your floors or the item while you're assembling the product.

Keep all components and packaging out of reach of children or animals to avoid risk of choking or suffocation.

Furniture components:

1	Top Panel	x1	10	Drawer Right	x2
2	Right Side Panel	x1	11	Drawer Left	x2
3	Left Side Panel	x1	12	Drawer Head A	x1
4	Bottom Panel	x1	13	Drawer Base	x2
5	Back Panel	x1	14	Drawer Back	x2
6	Front Leg Panel	x1	15	Drawer Head B	x1
7	Back Leg Panel	x1			
8	Right Leg Support	x1			
9	Left Leg Support	x1			

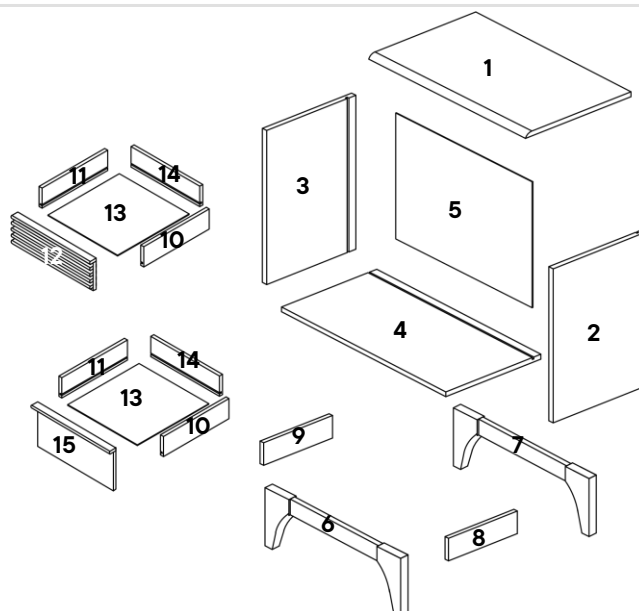

Provided hardware:

A		JCBC M6 x 70mm	x2	J		Drawer Runner Right	x2
B		Wooden Dowel Ø6 x 30mm	x28	K		JCBC M6 X 60mm	x2
C		Cam Lock- Ø15 x 12mm	x8	L		Cam Lock- Ø12 x 9.9mm	x4
D		Cam Bolt- Ø6 x 32mm	x12	M		Plastic Corner Block	x4
E		Floor Glide-B321	x4	N		JCBCW M6 x 50mm	x4
F		C/board Screw Ø3.5 x 16mm	x28	O		Screw Ø4 x 19mm	x4
G		C/board Runner Left	x2	P		C/board Screw Ø4 x 38mm	x4
H		C/board Runner Right	x2	Q		Allen Key	x1
I		Drawer Runner Left	x2				

What you need:



Wait!

Missing parts or hardware? Need assistance?

Contact us before returning your item. We're here to help!
609.256.9000 • cs@modway.com

Step 1

HARDWARE

- B** Wooden Dowel Ø6 x 30mm x20
- E** Floor Glide-B321 x4
- F** C/board Screw Ø3.5 x 16mm x4

COMPONENTS

- 2** Right Side Panel x1
- 3** Left Side Panel x1
- 6** Front Leg Panel x1
- 7** Back Leg Panel x1
- 8** Right Leg Support x1
- 9** Left Leg Support x1

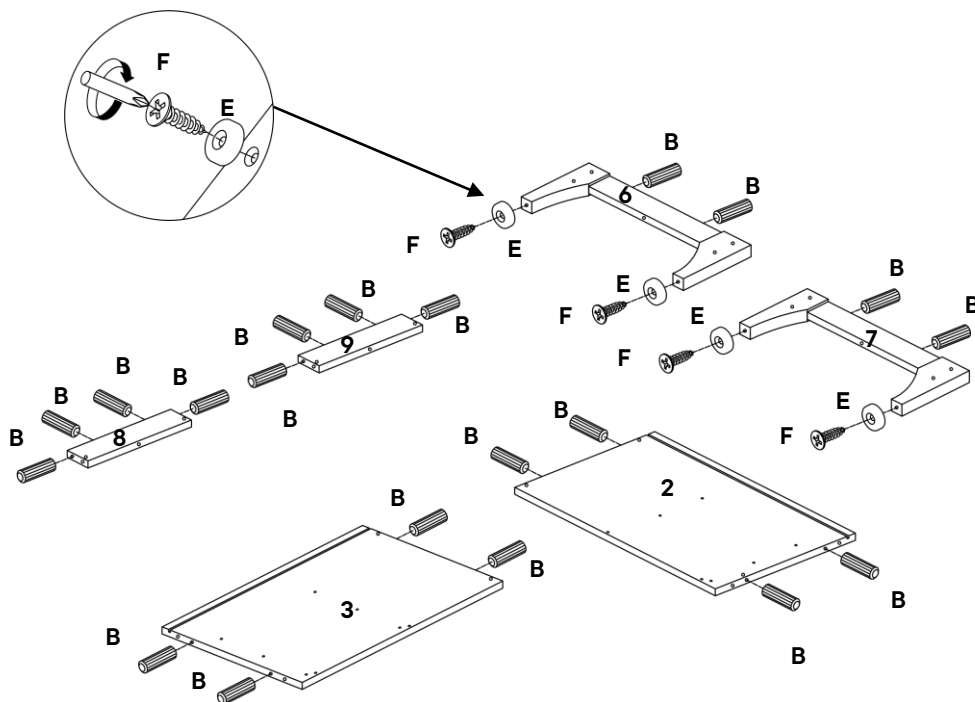

Step 2

HARDWARE

- D** Cam Bolt- Ø6 x 32mm x8

COMPONENTS

- 1** Top Panel x1
- 6** Front Leg Panel x1
- 7** Back Leg Panel x1

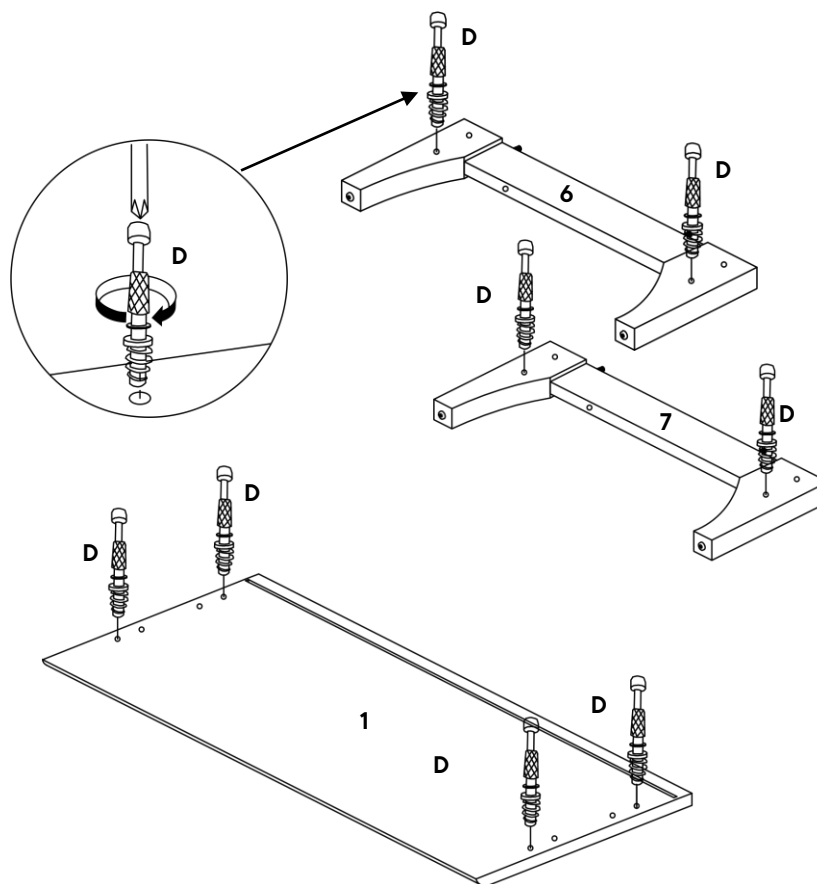

Step 3

HARDWARE

C Cam Lock- Ø15 x 12mm x2

COMPONENTS

6 Front Leg Panel x1

8 Right Leg Support x1

9 Left Leg Support x1

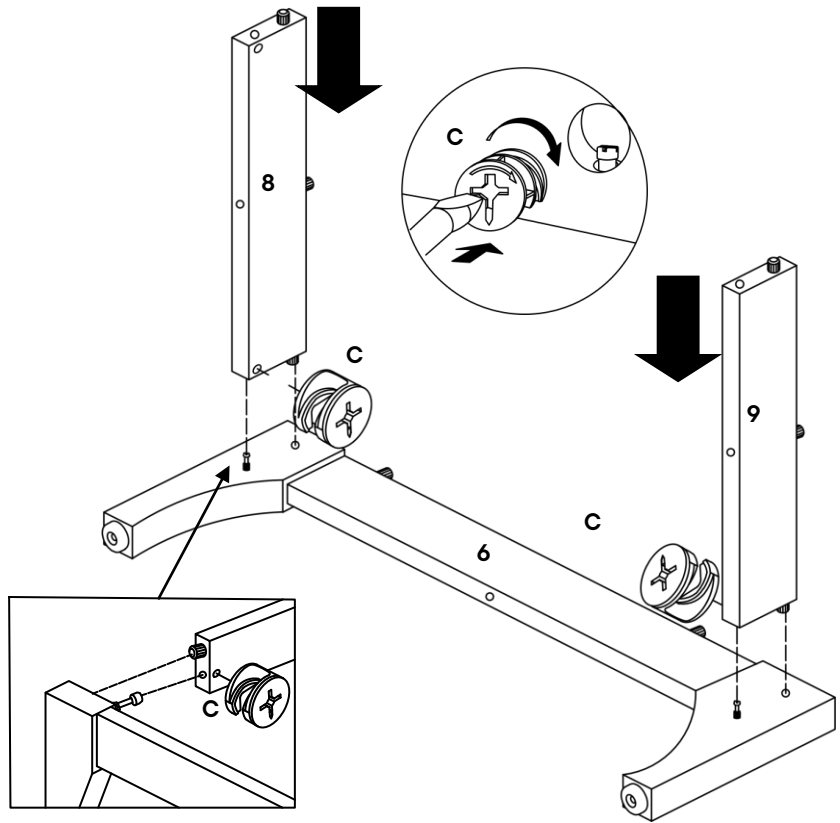

Step 4

HARDWARE

C Cam Lock- Ø15 x 12mm x2

COMPONENTS

7 Back Leg Panel x1

8 Right Leg Support x1

9 Left Leg Support x1

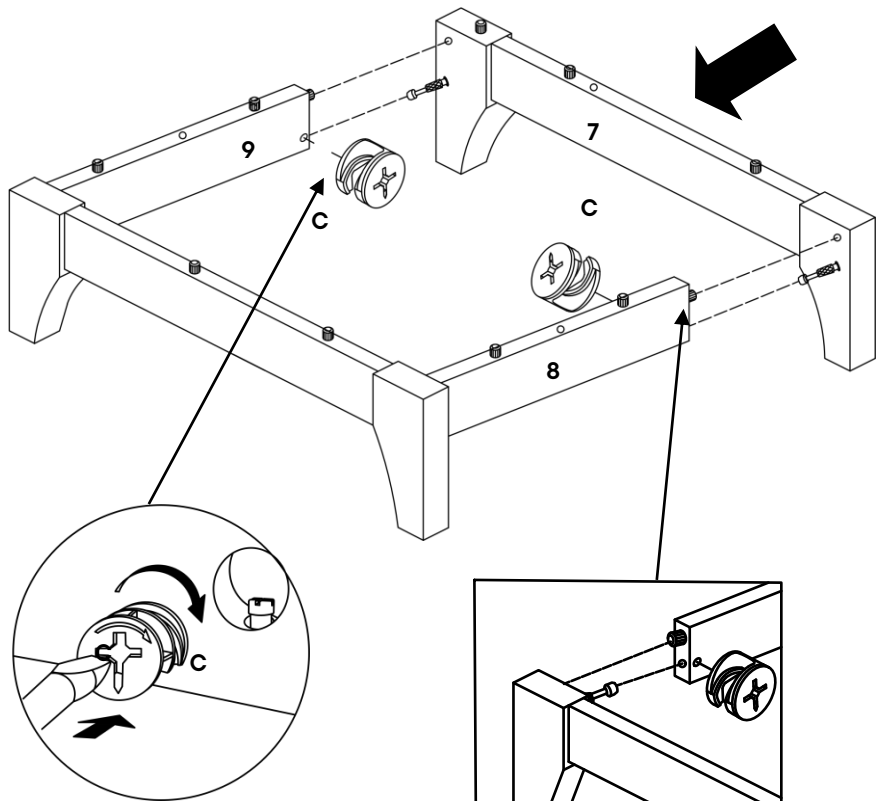

Step 5

HARDWARE

- F** C/board Screw Ø3.5 x 16mm x12
- G** C/board Runner Left x2
- H** C/board Runner Right x2

COMPONENTS

- 2** Right Side Panel x1
- 3** Left Side Panel x1

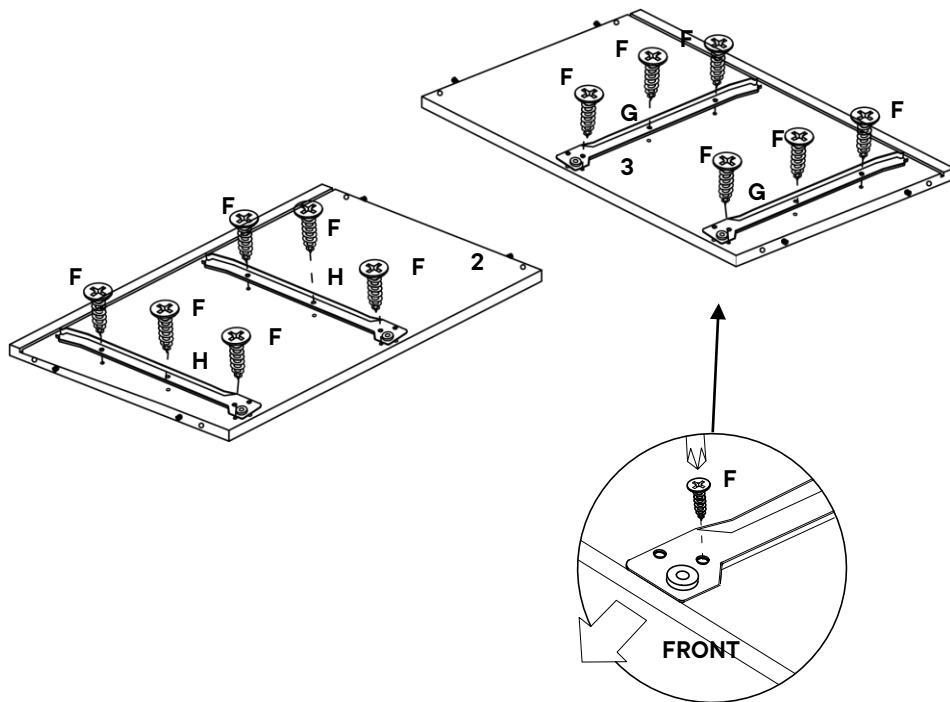

Step 6

HARDWARE

- N** JCBCW M6 x 50mm x4
- Q** Allen Key x1

COMPONENTS

- 2** Right Side Panel x1
- 3** Left Side Panel x1
- 4** Bottom Panel x1

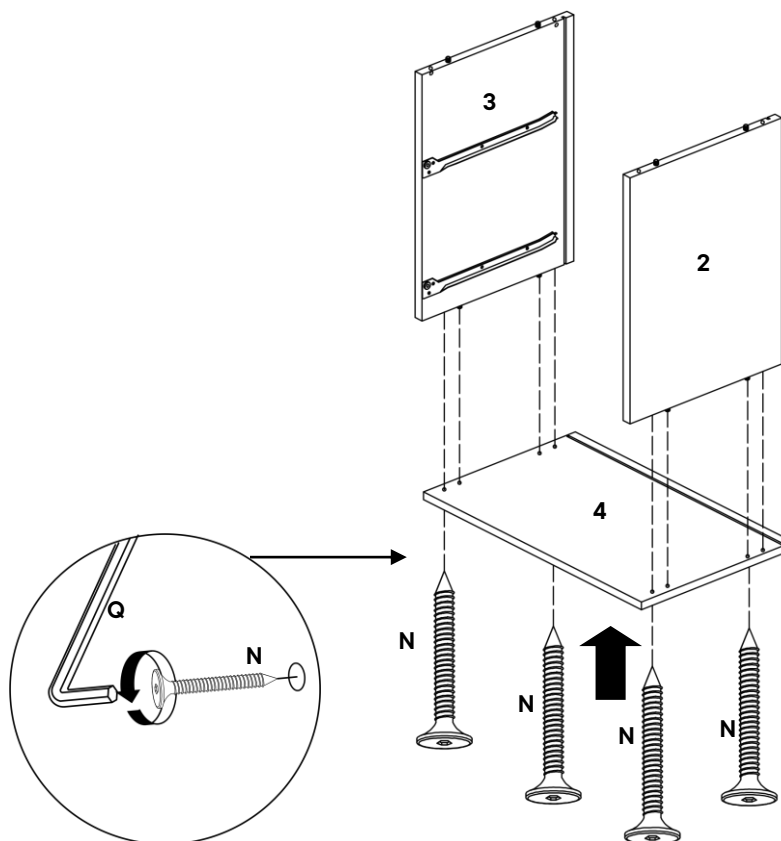

Step 7

HARDWARE

- A** JCBC M6 x 70mm x2
- K** JCBC M6 x 60mm x2
- Q** Allen Key x1

COMPONENTS

- 2** Right Side Panel x1
- 3** Left Side Panel x1
- 4** Bottom Panel x1
- 6** Front Leg Panel x1
- 7** Back Leg Panel x1

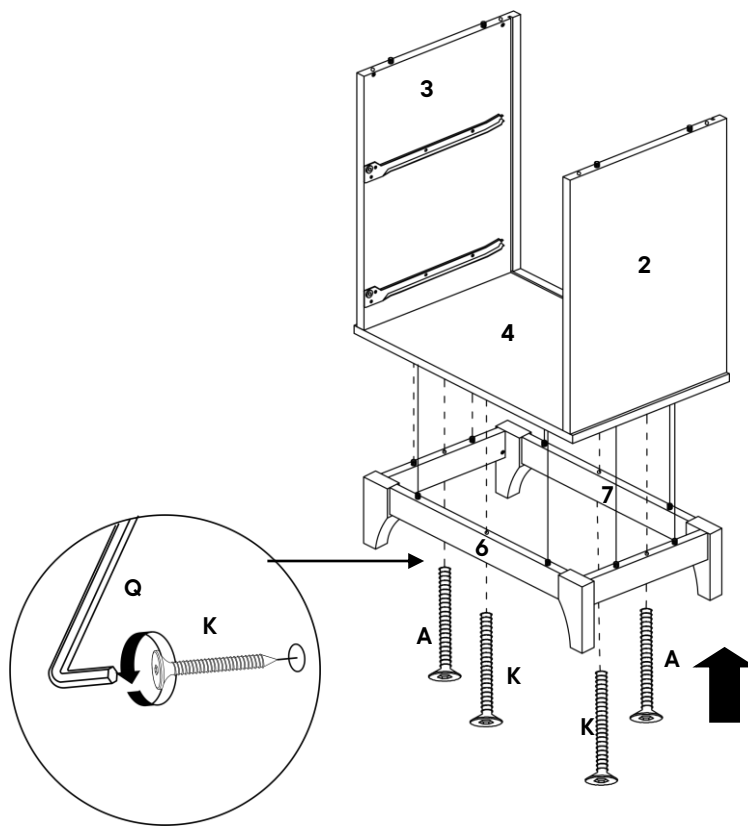

Step 8

COMPONENTS

- 5** Back Panel x1

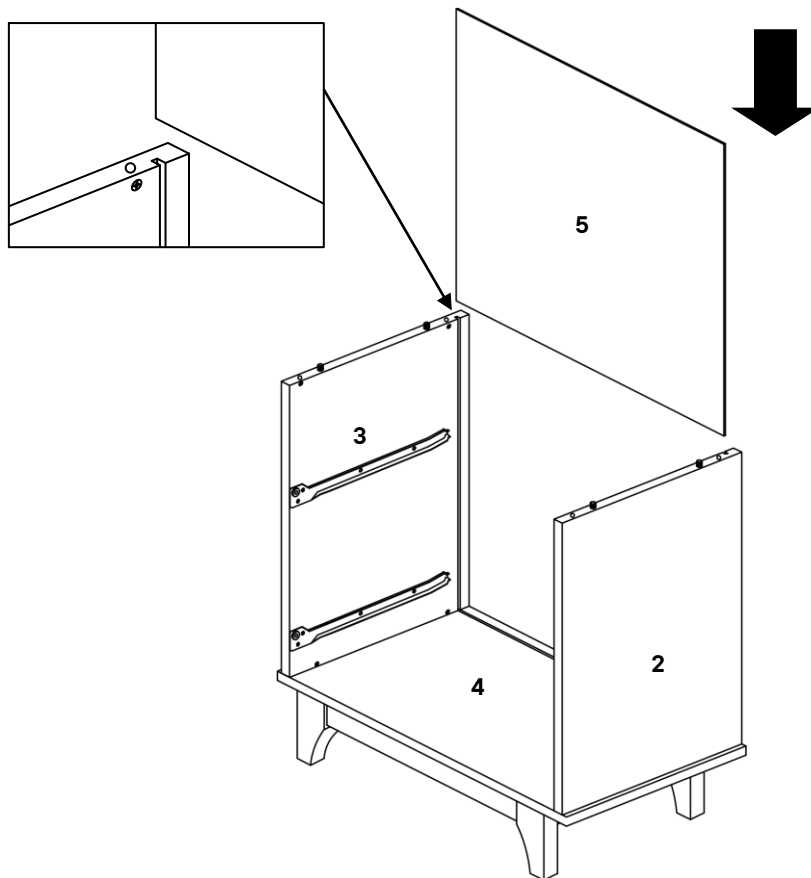

Step 9

HARDWARE

C Cam Lock- Ø15 x 12mm x4

COMPONENTS

1 Top Panel x1

2 Right Side Panel x1

3 Left Side Panel x1

5 Back Panel x1

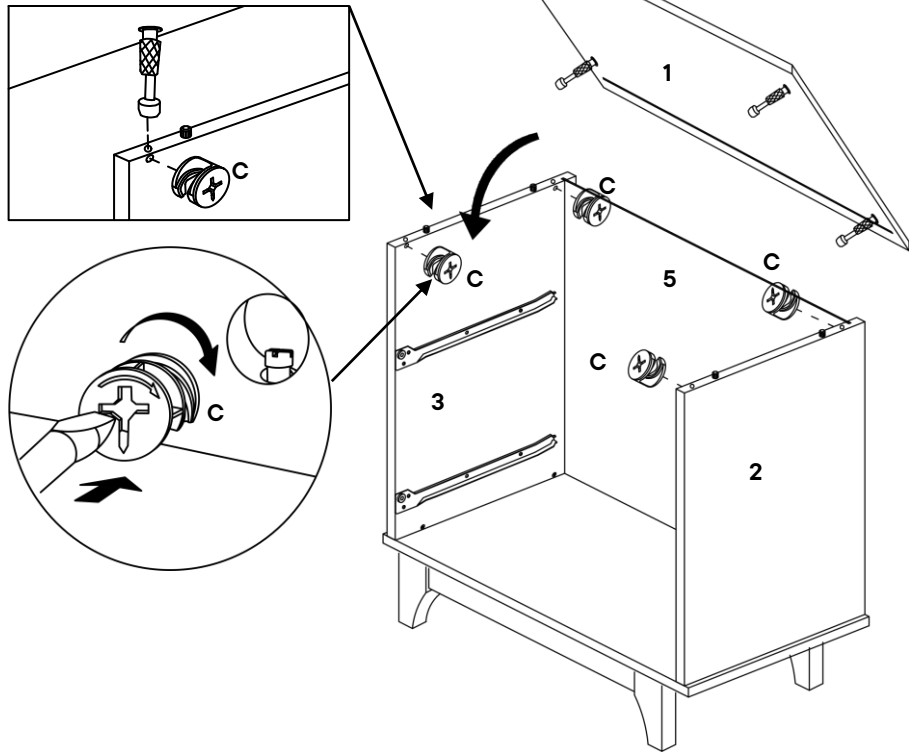

Step 10

HARDWARE

O Screw Ø4 x 19mm x4

M Plastic Corner Block x4

COMPONENTS

5 Back Panel x1

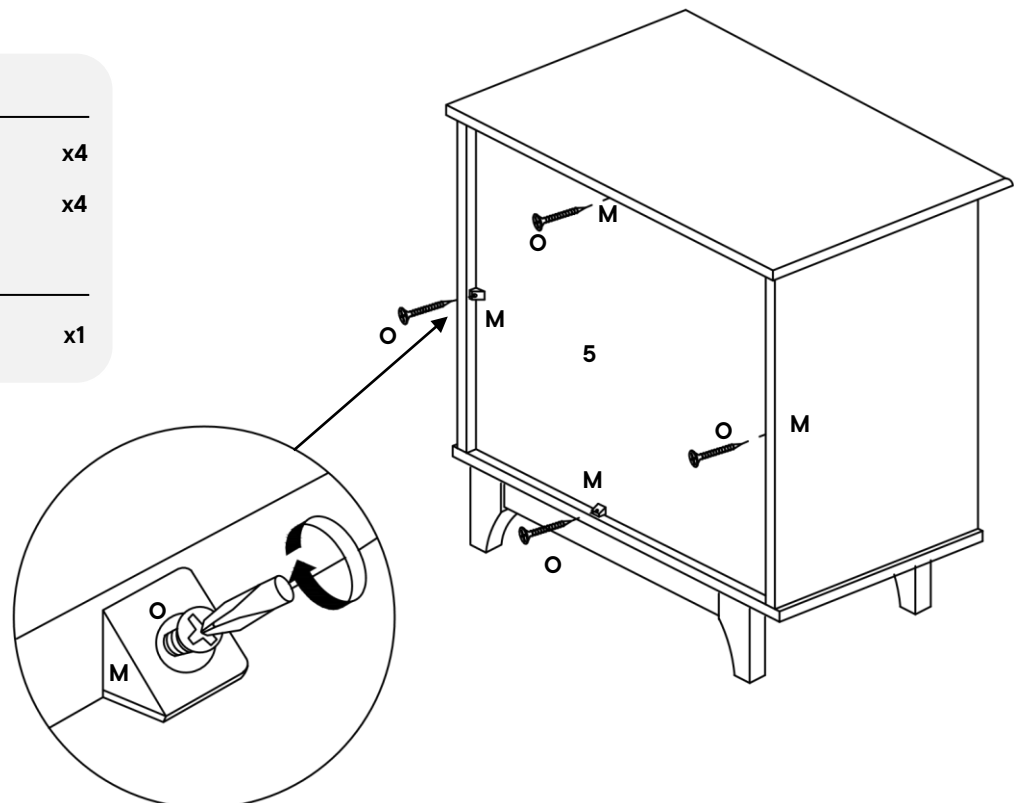

Step 11

HARDWARE

B Wooden Dowel Ø6 x 30mm x8

COMPONENTS

10 Drawer Right x2

11 Drawer Left x2

14 Drawer Back x2

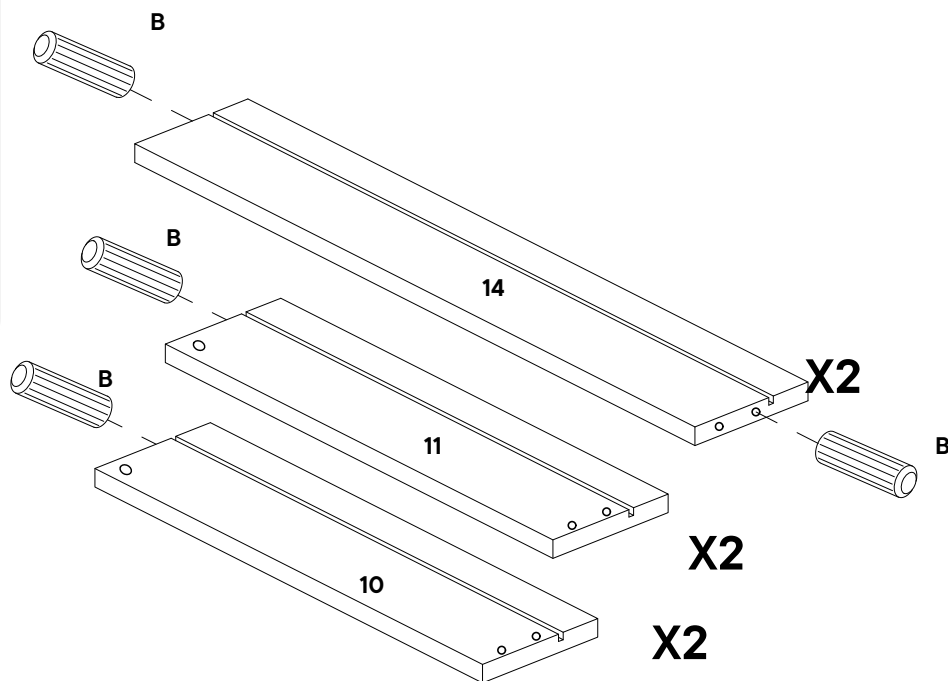

Step 12

HARDWARE

D Cam Bolt- Ø6 x 32mm x4

COMPONENTS

12 Drawer Head A x1

15 Drawer Head B x1

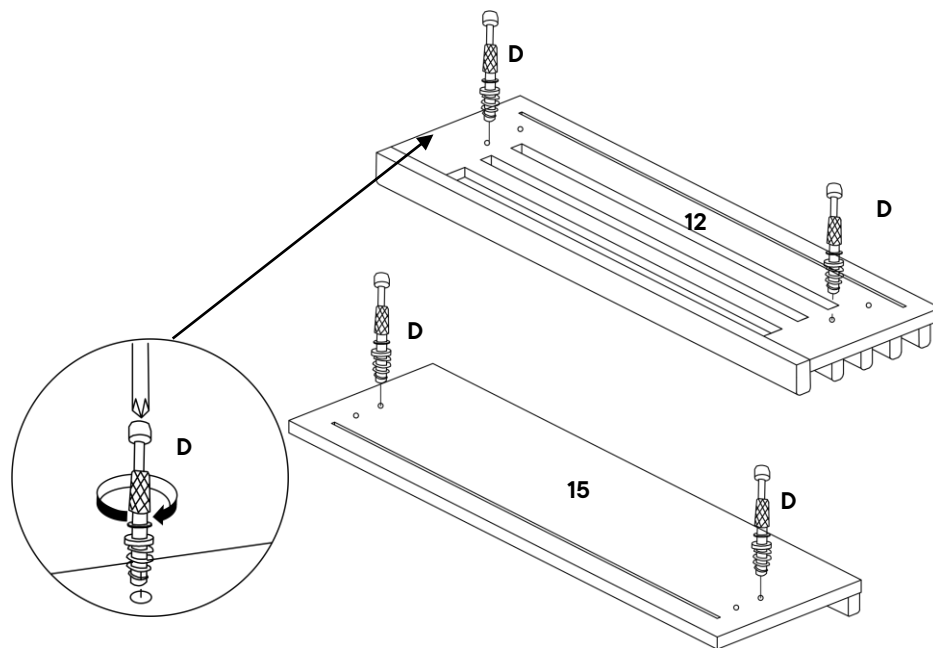

Step 13

HARDWARE

P C/board Screw $\varnothing 4 \times 38\text{mm}$ x4

COMPONENTS

10 Drawer Right x2

11 Drawer Left x2

14 Drawer Back x2

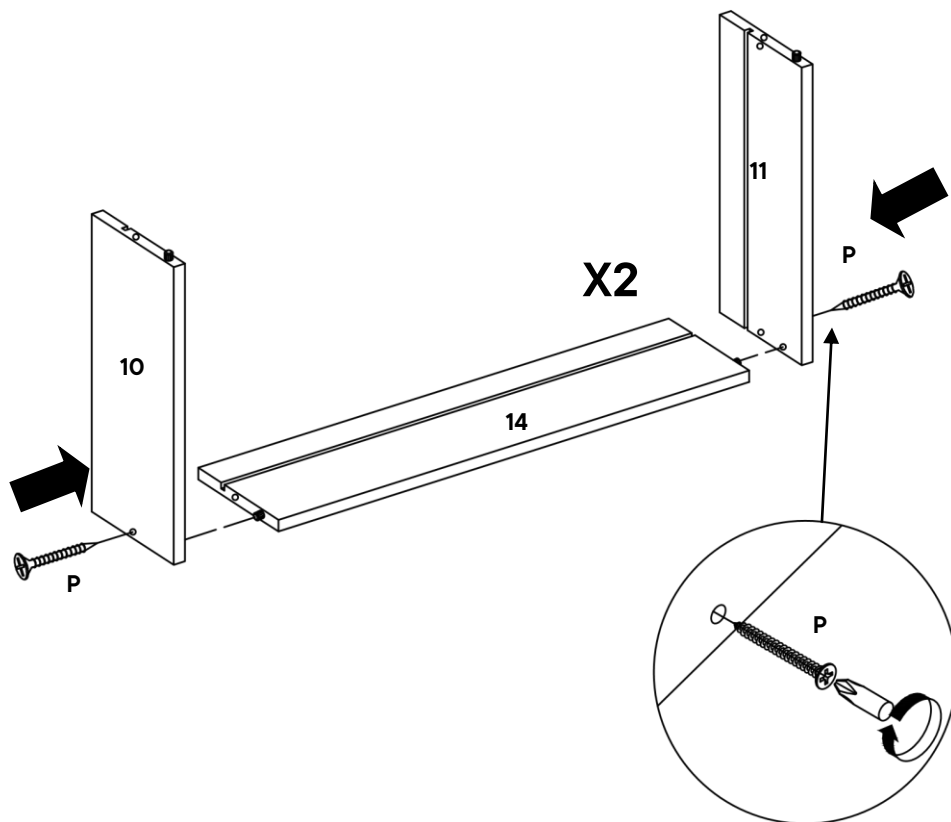

Step 14

HARDWARE

L Cam Lock- $\varnothing 12 \times 9.9\text{mm}$ x4

COMPONENTS

10 Drawer Right x2

11 Drawer Left x2

12 Drawer Head A x1

13 Drawer Base x2

14 Drawer Back x2

15 Drawer Head B x1

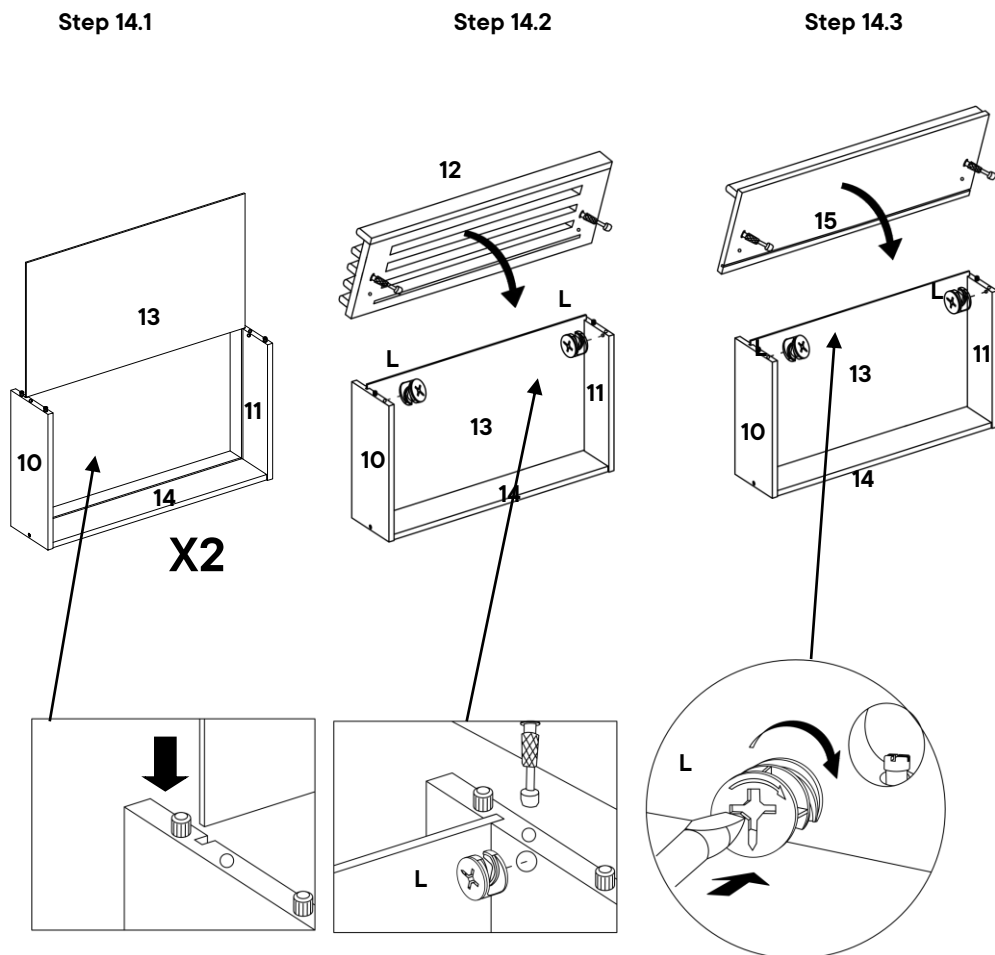

Step 15

HARDWARE

- F** C/board Screw $\varnothing 3.5 \times 16\text{mm}$ x12
- I** Drawer Runner Left x2
- J** Drawer Runner Right x2

COMPONENTS

- 10** Drawer Right x2
- 11** Drawer Left x2

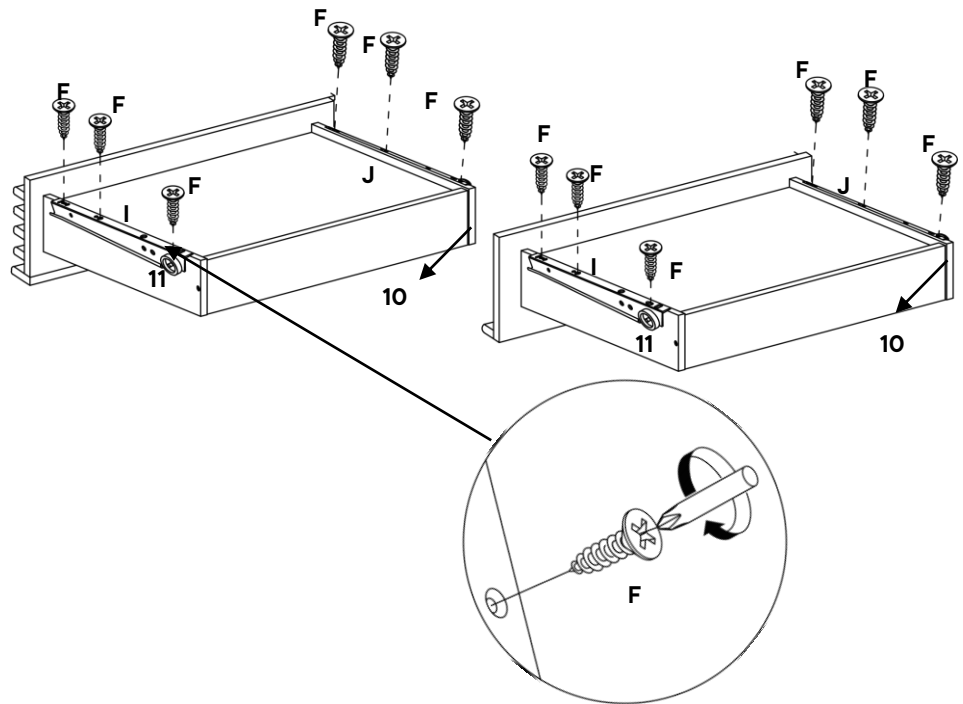

Step 16

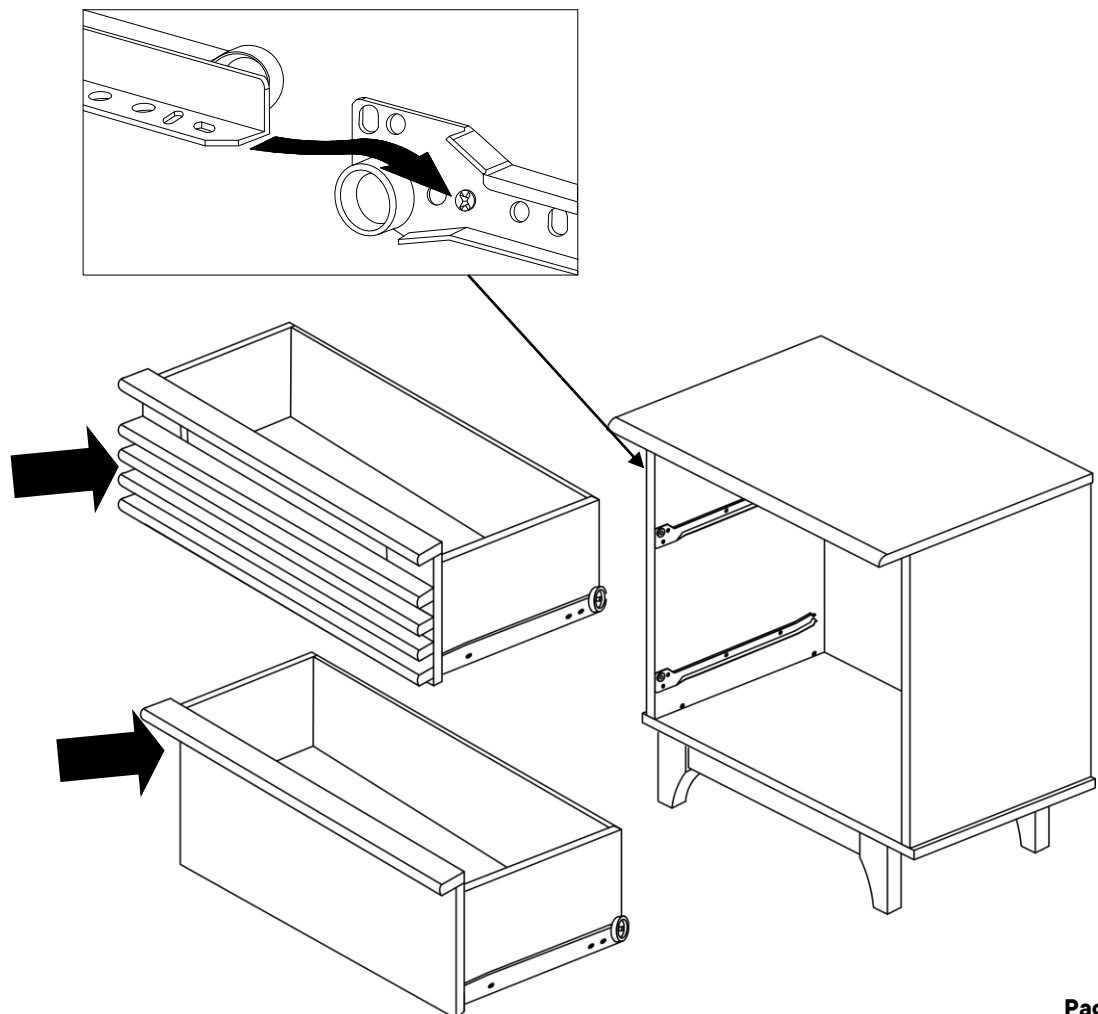

Great job!

Nightstand assembly is complete.

♥ CARING FOR YOUR ITEM

Indoor use only.

Not contract grade.

Clean using a non-abrasive cloth and a mild cleaner.

Never use harsh chemicals, as they could damage the finish or integrity of the item.

CONNECT WITH US!

Tag us [@modway_furniture](#) and [#modway](#) for a chance to be featured.

