

ASSEMBLY INSTRUCTIONS

MOD-7068

V2. 01.10.22

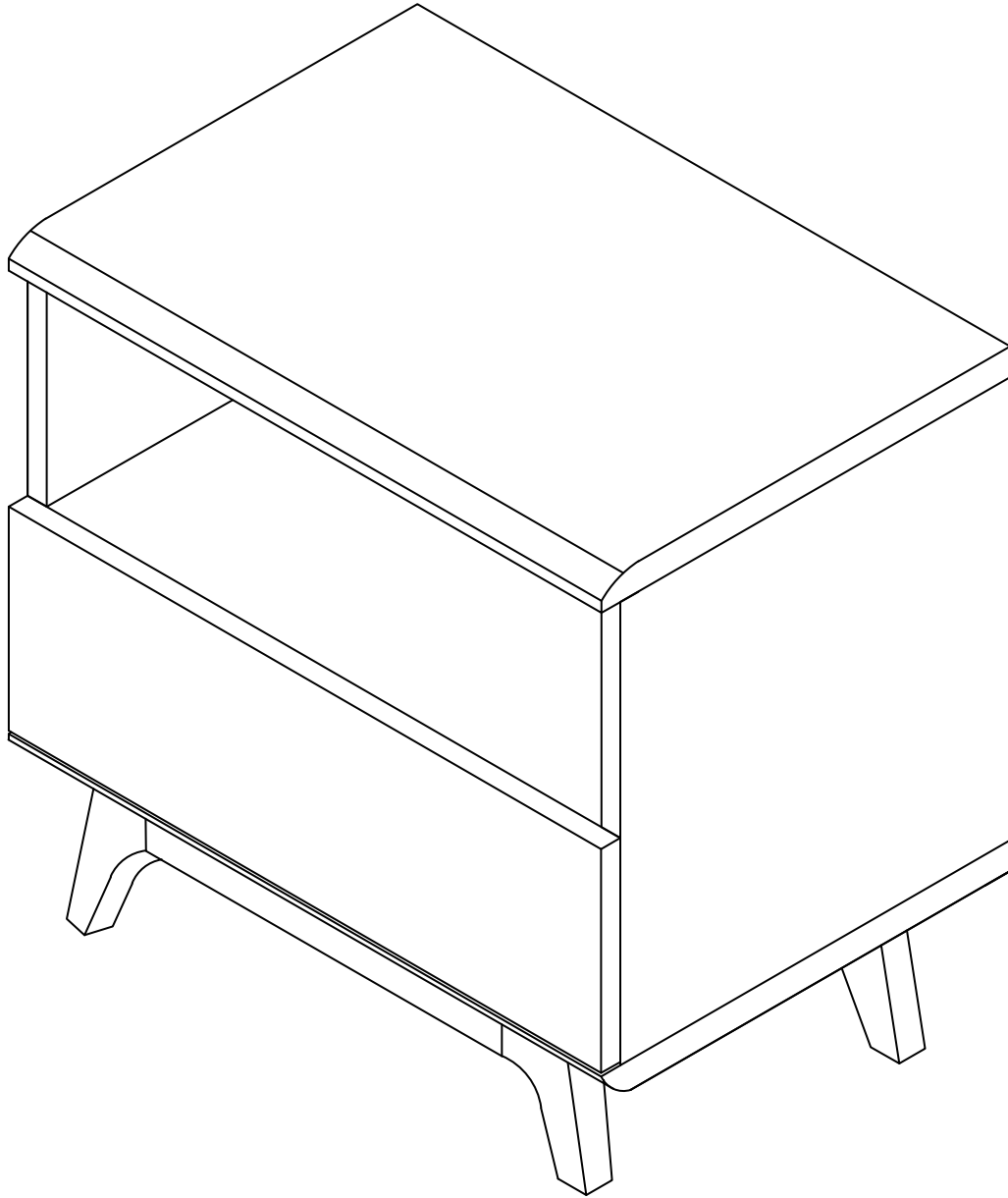

Questions? Contact us!

609.256.9000 • cs@modway.com
www.modway.com

***modway**

Let's get started!



Read through all of the instructions before starting



Care instructions are listed in the last step of this manual



Approx. 60 minutes assembly time



Make sure you have all parts and components before discarding any packing materials



2 people recommended for assembly

Only use hand tools to assemble this item. Do not use power tools. Do not tighten bolts or screws completely until all hardware is lined up and inserted into the holes.

Do not over-tighten screws and bolts to avoid stripping the hardware or cracking the item.

Assemble your item on a flat, carpeted area, with plenty of space to work. This will prevent damage and scratches to your floors or the item while you're assembling the product.

Keep all components and packaging out of reach of children or animals to avoid risk of choking or suffocation.

Furniture components:

1	Top Panel	x1	10	Drawer Right	x1
2	Right Side Panel	x1	11	Drawer Left	x1
3	Left Side Panel	x1	12	Drawer Head	x1
4	Bottom Panel	x1	13	Drawer Base	x1
5	Back Panel	x1	14	Drawer Back	x1
6	Front Leg Panel	x1	15	Fixed Shelf	x1
7	Back Leg Panel	x1			
8	Right Leg Support	x1			
9	Left Leg Support	x1			

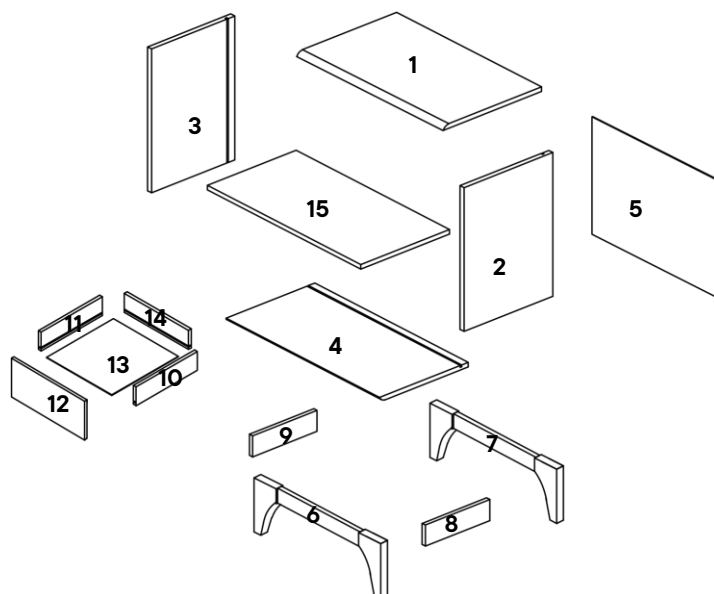

Provided hardware:

A		JCBC M6 x 70mm	x2	J		Drawer Runner Right	x1	S		Cam Lock Cap	x4
B		Wooden Dowel Ø6 x 30mm	x28	K		JCBC M6 X 60mm	x2				
C		Cam Lock- Ø15 x 12mm	x12	L		Cam Lock- Ø12 x 9.9mm	x2				
D		Cam Bolt- Ø6 x 32mm	x14	M		Plastic Corner Block	x4				
E		Floor Glide-B321	x4	N		JCBCW M6 x 50mm	x4				
F		C/board Screw Ø3.5 x 16mm	x20	O		Screw Ø4 x 19mm	x4				
G		C/board Runner Left	x1	P		C/board Screw Ø4 x 38mm	x2				
H		C/board Runner Right	x1	Q		Allen Key	x1				
I		Drawer Runner Left	x1	R		Push Mechanism	x2				

What you need:

Phillips Head Screwdriver

Wait!

Missing parts or hardware? Need assistance?

Contact us before returning your item. We're here to help!
609.256.9000 • cs@modway.com

Step 1

HARDWARE

- B** Wooden Dowel Ø6 x 30mm x24
- D** Cam Bolt- Ø6 x 32mm x4
- E** Floor Glide-B321 x4
- F** C/board Screw Ø3.5 x 16mm x4

COMPONENTS

- 2** Right Side Panel x1
- 3** Left Side Panel x1
- 6** Front Leg Panel x1
- 7** Back Leg Panel x1
- 8** Right Leg Support x1
- 9** Left Leg Support x1
- 15** Fixed Shelf x1

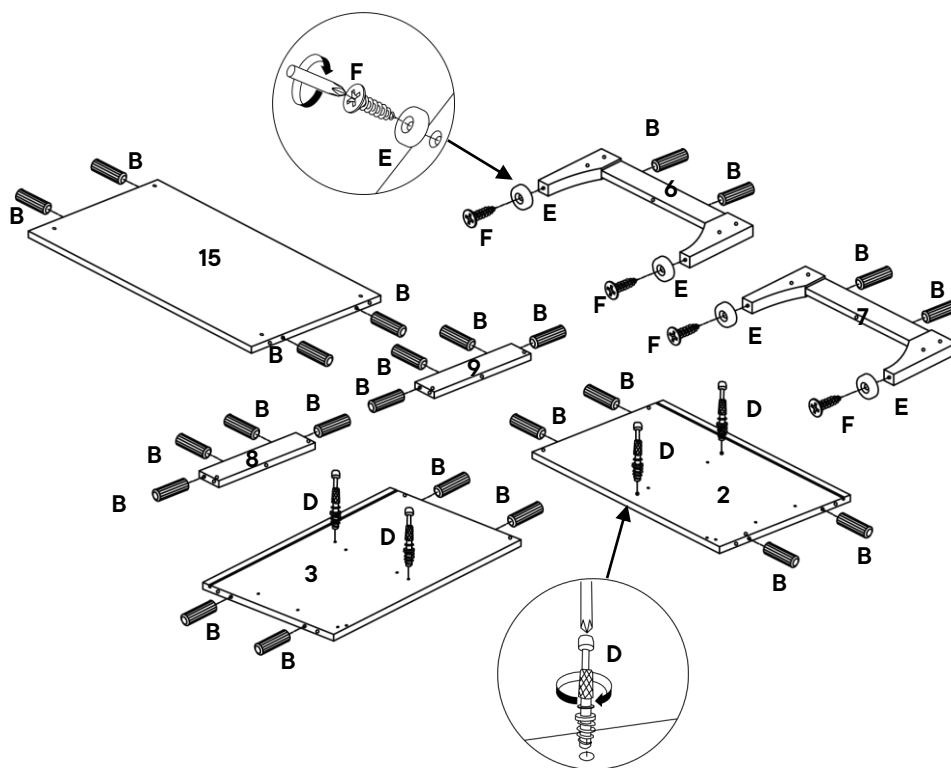

Step 2

HARDWARE

- D** Cam Bolt- Ø6 x 32mm x8

COMPONENTS

- 1** Top Panel x1
- 6** Front Leg Panel x1
- 7** Back Leg Panel x1

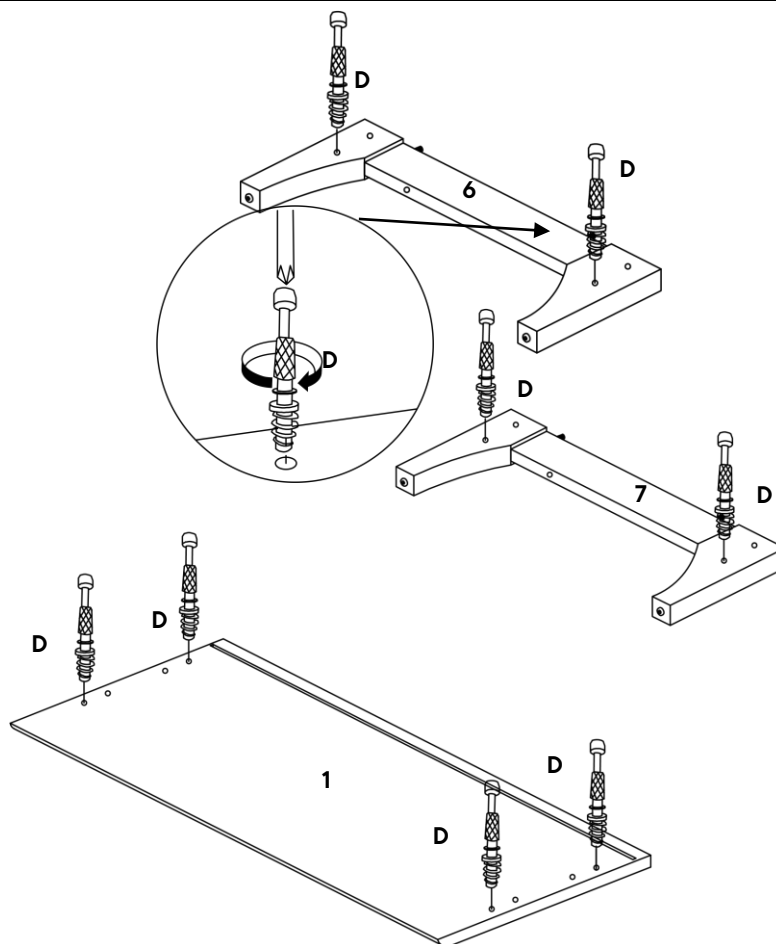

Step 3

HARDWARE

- C** Cam Lock- Ø15 x 12mm x2

COMPONENTS

- 6** Front Leg Panel x1
- 8** Right Leg Support x1
- 9** Left Leg Support x1

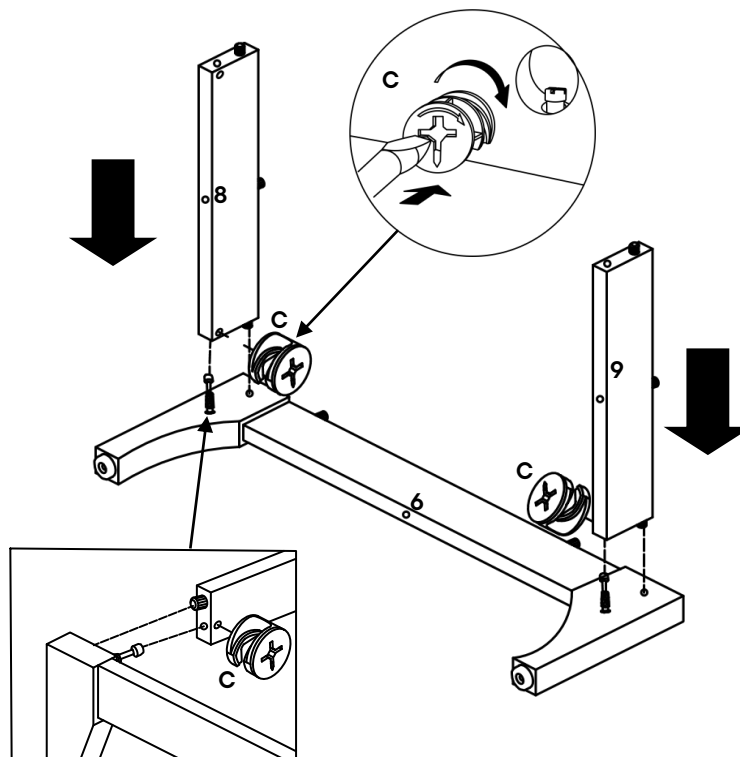

Step 4

HARDWARE

- C** Cam Lock- Ø15 x 12mm x2

COMPONENTS

- 7** Back Leg Panel x1
- 8** Right Leg Support x1
- 9** Left Leg Support x1

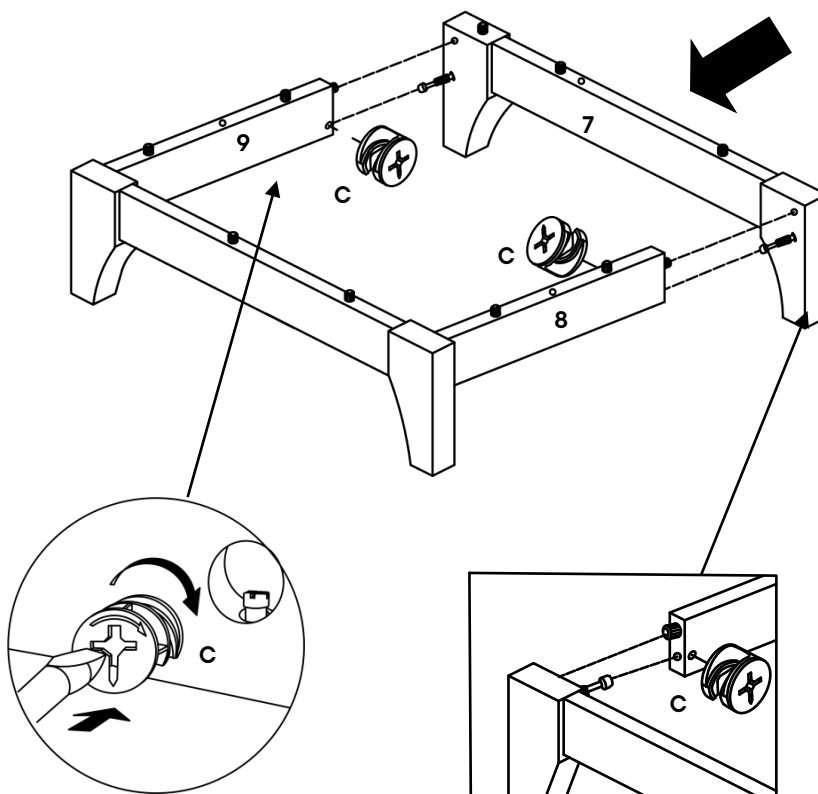

Step 5

HARDWARE

- F** C/board Screw Ø3.5 x 16mm x10
- G** C/board Runner Left x1
- H** C/board Runner Right x1
- R** Push Mechanism x2

COMPONENTS

- 2** Right Side Panel x1
- 3** Left Side Panel x1

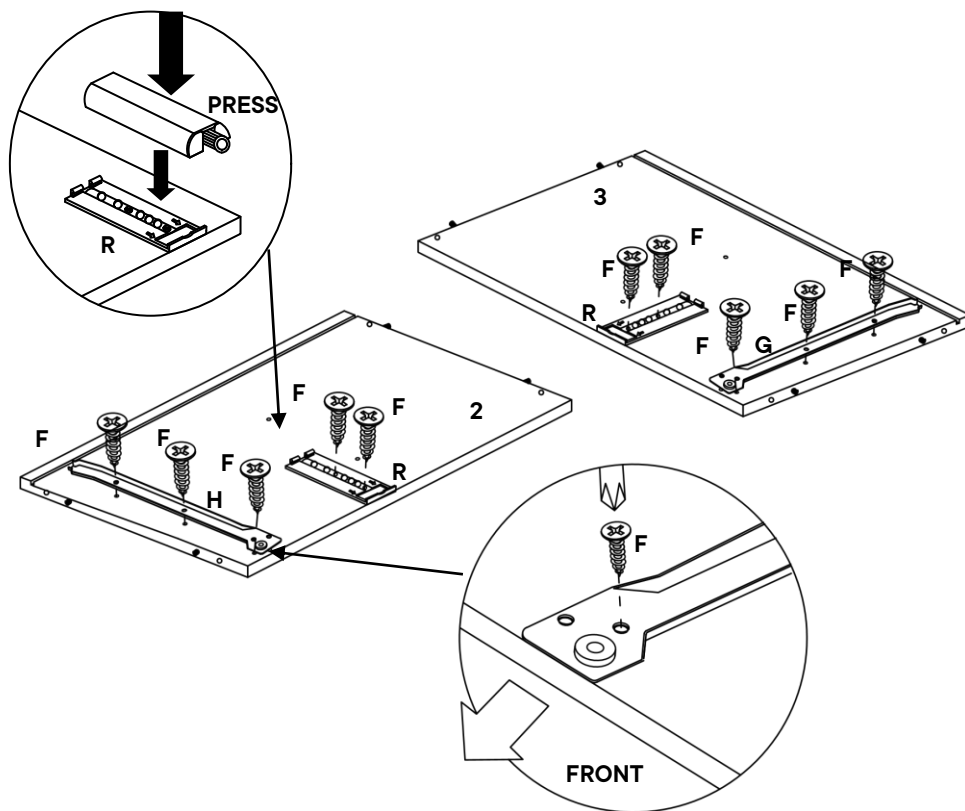

Step 6

HARDWARE

- C** Cam Lock- Ø15 x 12mm x4

COMPONENTS

- 2** Right Side Panel x1
- 3** Left Side Panel x1
- 15** Fixed Shelf x1

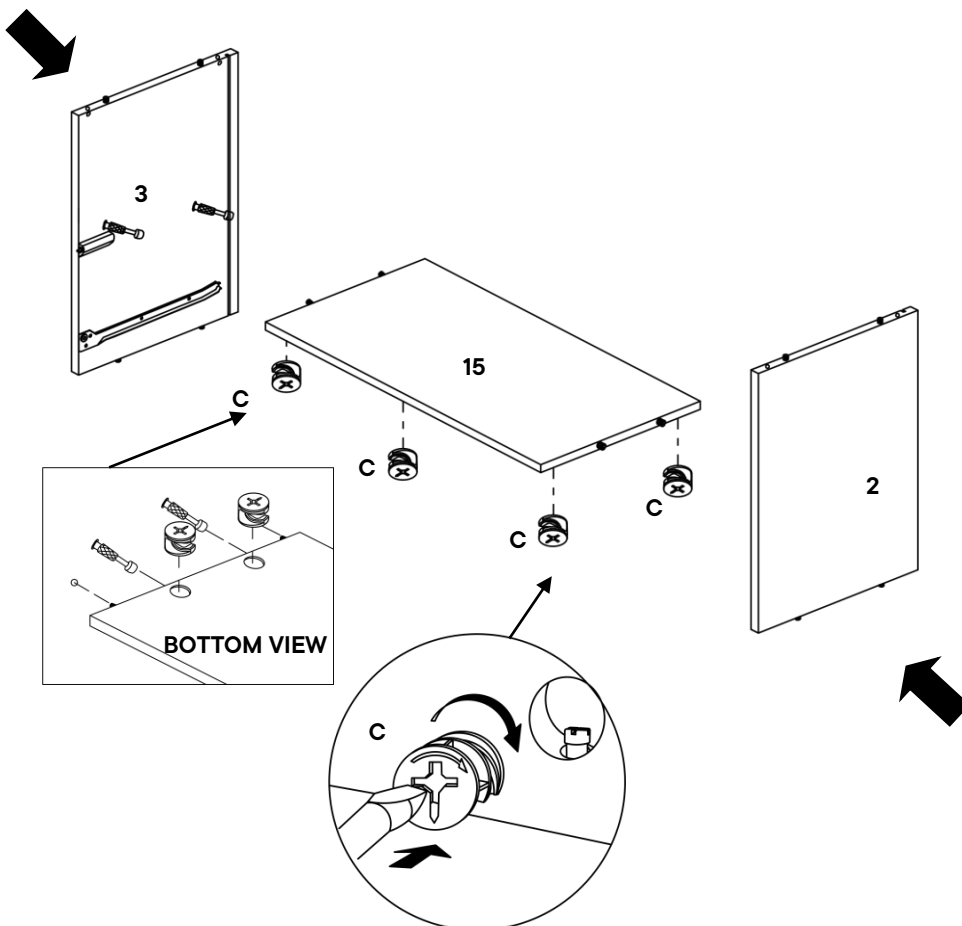

Step 7

HARDWARE

N JCBCW M6 x 50mm x4

Q Allen Key x1

COMPONENTS

2 Right Side Panel x1

3 Left Side Panel x1

4 Bottom Panel x1

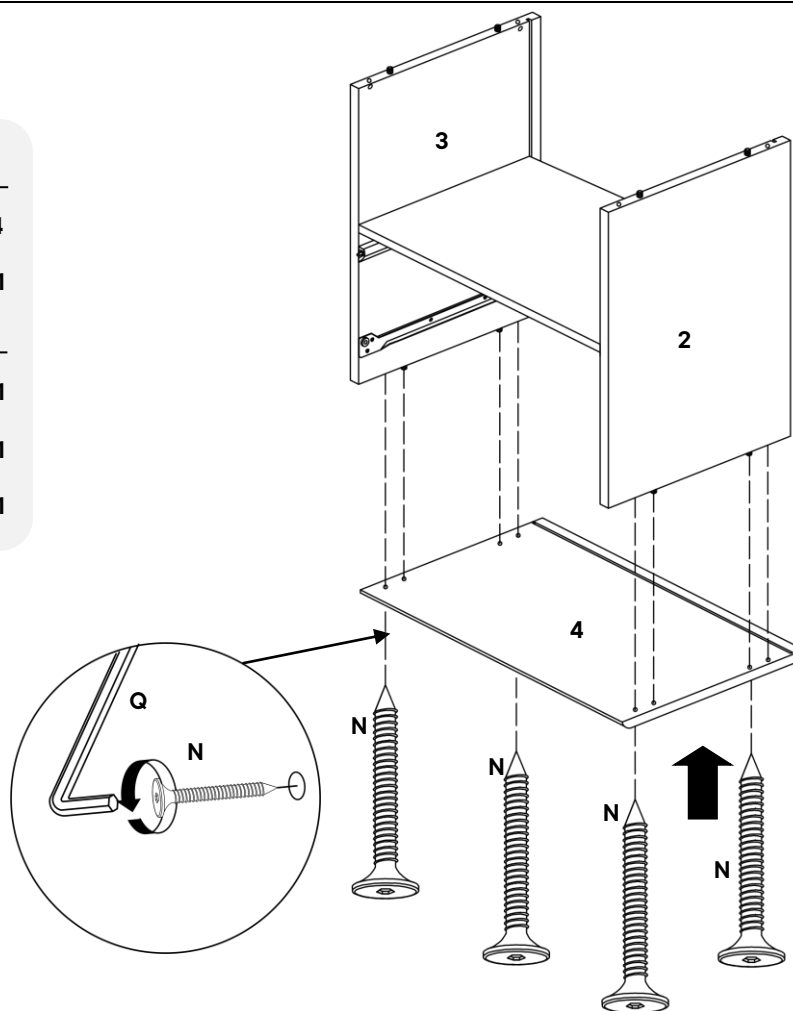

Step 8

HARDWARE

A JCBC M6 x 70mm x2

K JCBC M6 x 60mm x2

Q Allen Key x1

COMPONENTS

2 Right Side Panel x1

3 Left Side Panel x1

4 Bottom Panel x1

6 Front Leg Panel x1

7 Back Leg Panel x1

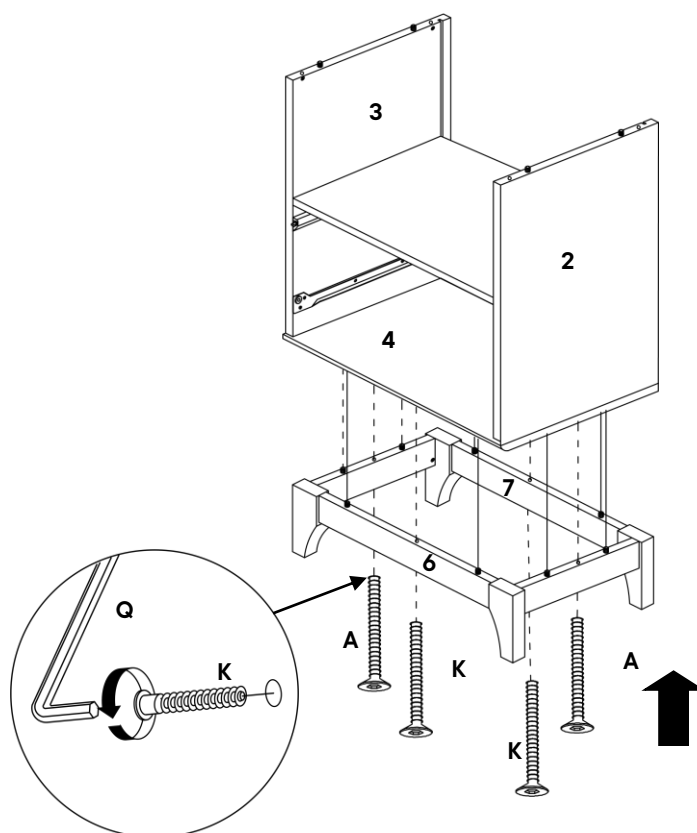

Step 9

COMPONENTS

- 5** Back Panel x1

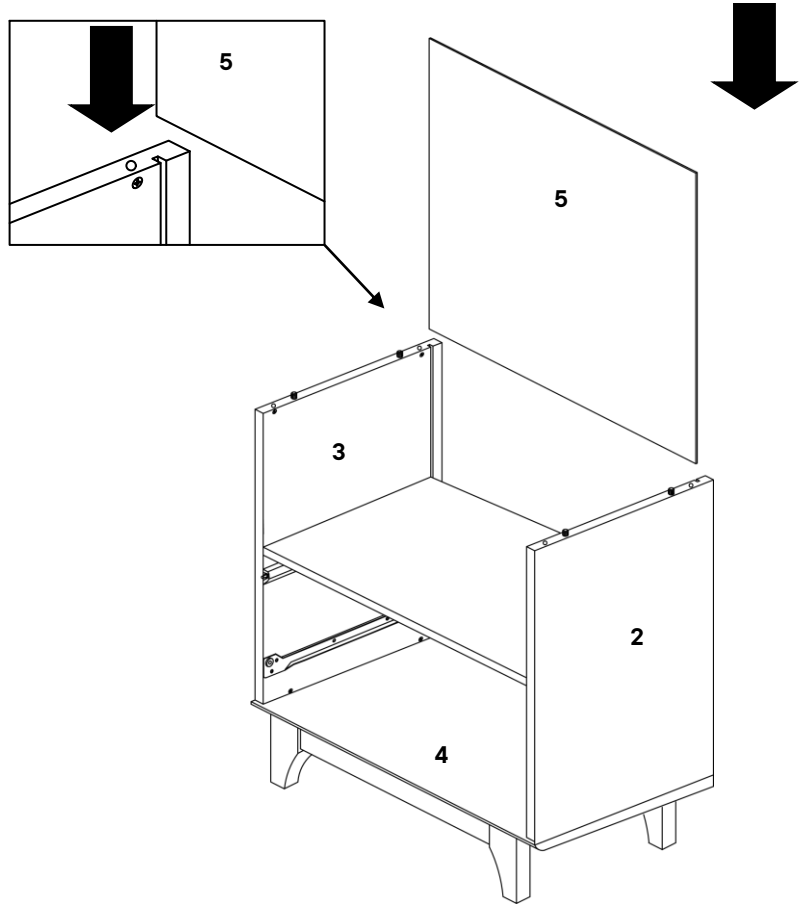

Step 10

HARDWARE

- C** Cam Lock- Ø15 x 12mm x4
- S** Cam Lock Cap x4

COMPONENTS

- 1** Top Panel x1
- 2** Right Side Panel x1
- 3** Left Side Panel x1
- 5** Back Panel x1

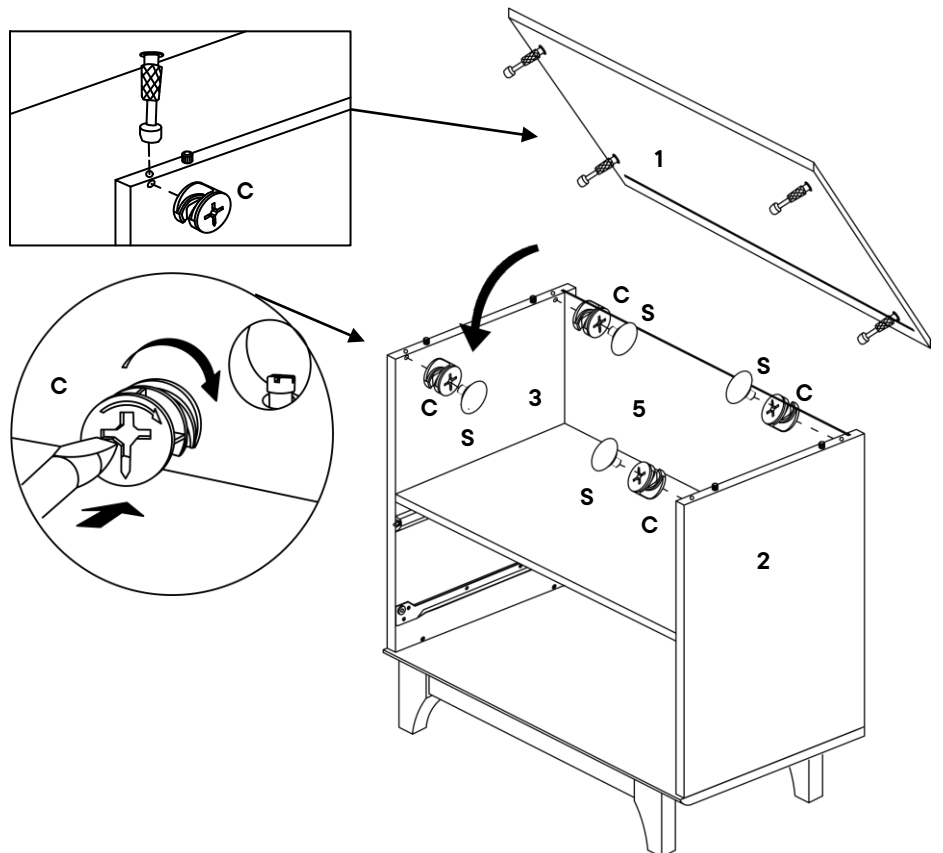

Step 11

HARDWARE

- O** Screw Ø4 x 19mm x4
- M** Plastic Corner Block x4

COMPONENTS

- 5** Back Panel x1

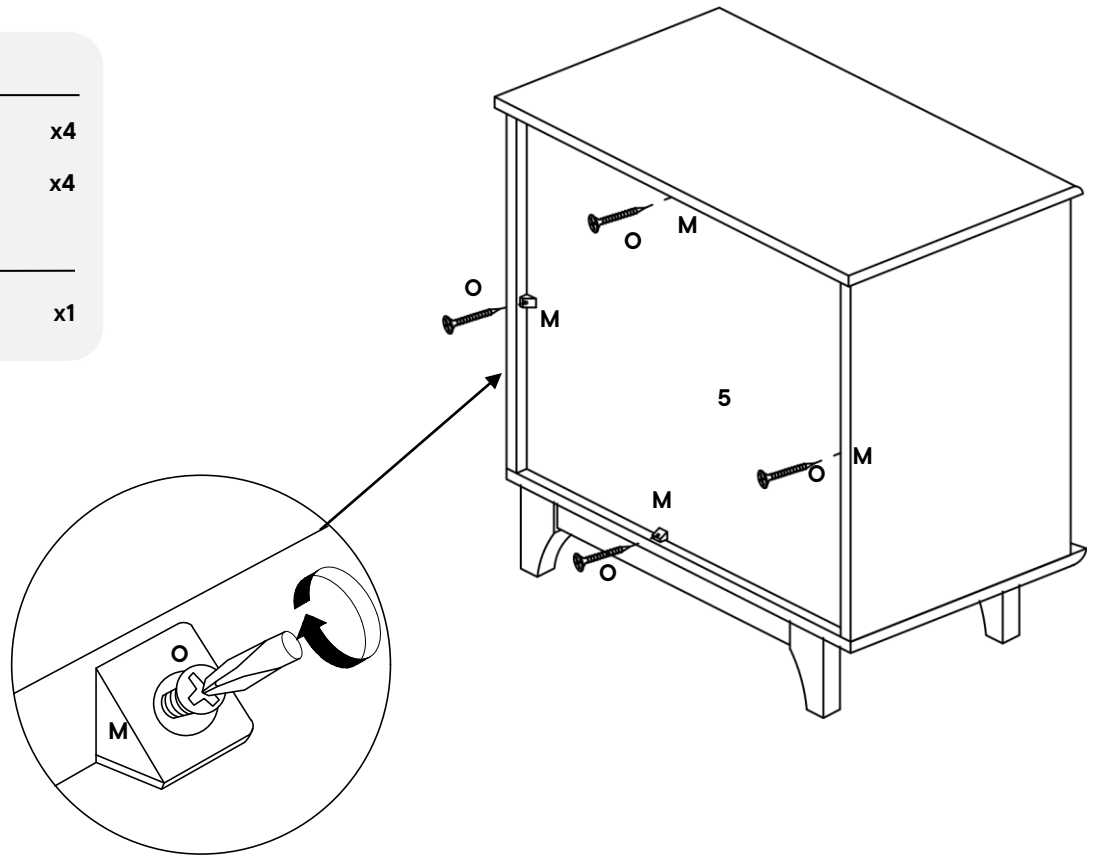

Step 12

HARDWARE

- B** Wooden Dowel Ø6 x 30mm x4

COMPONENTS

- 10** Drawer Right x1
- 11** Drawer Left x1
- 14** Drawer Back x1

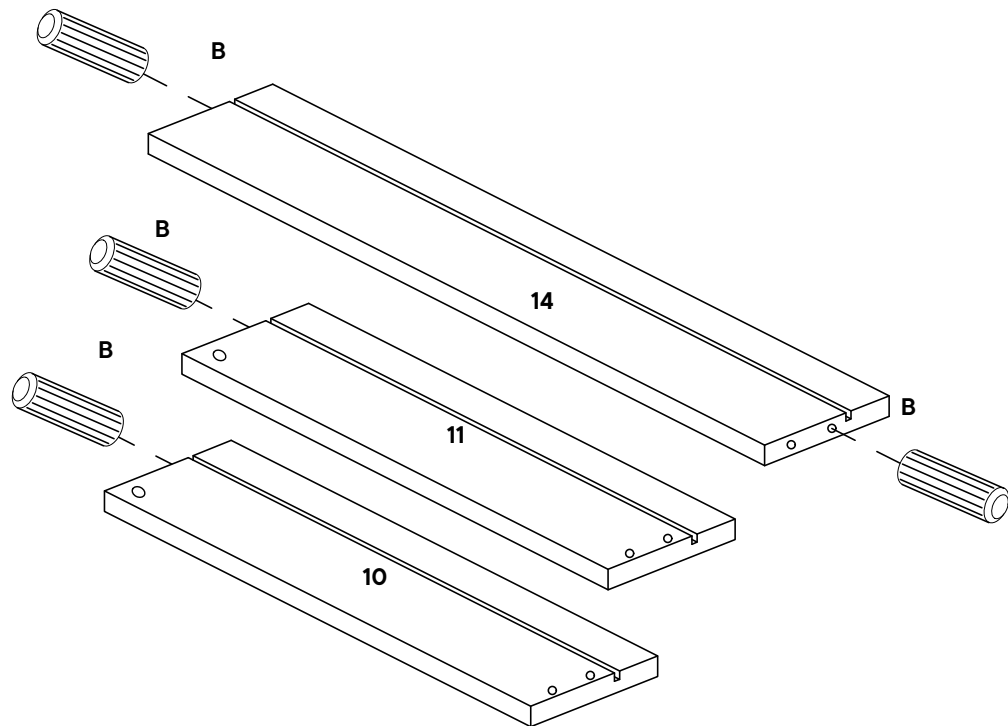

Step 13

HARDWARE

D Cam Bolt- Ø6 x 32mm x2

COMPONENTS

12 Drawer Head x1

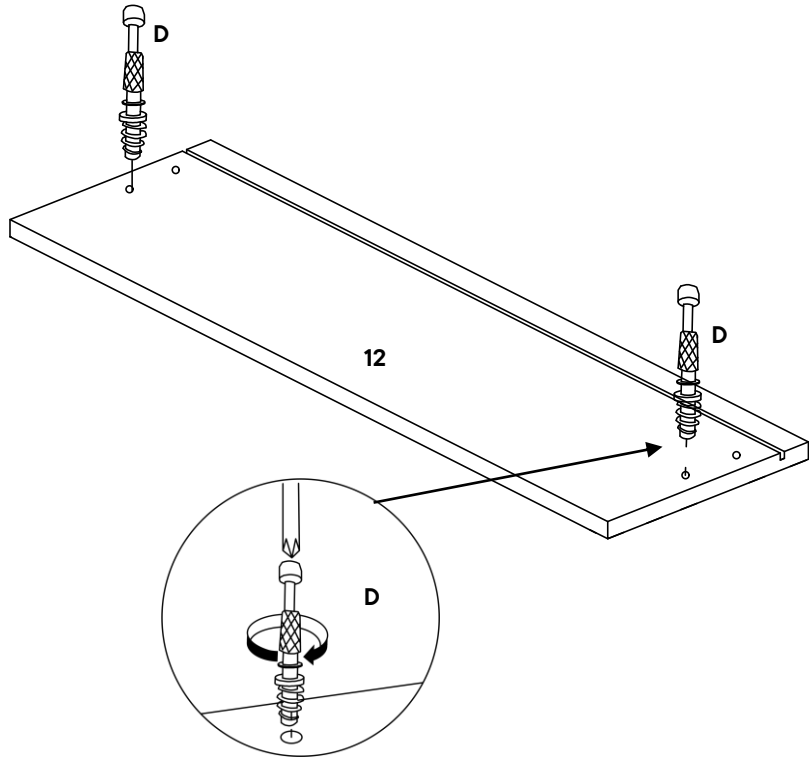

Step 14

HARDWARE

P C/board Screw Ø4 x 38mm x2

COMPONENTS

10 Drawer Right x1

11 Drawer Left x1

14 Drawer Back x1

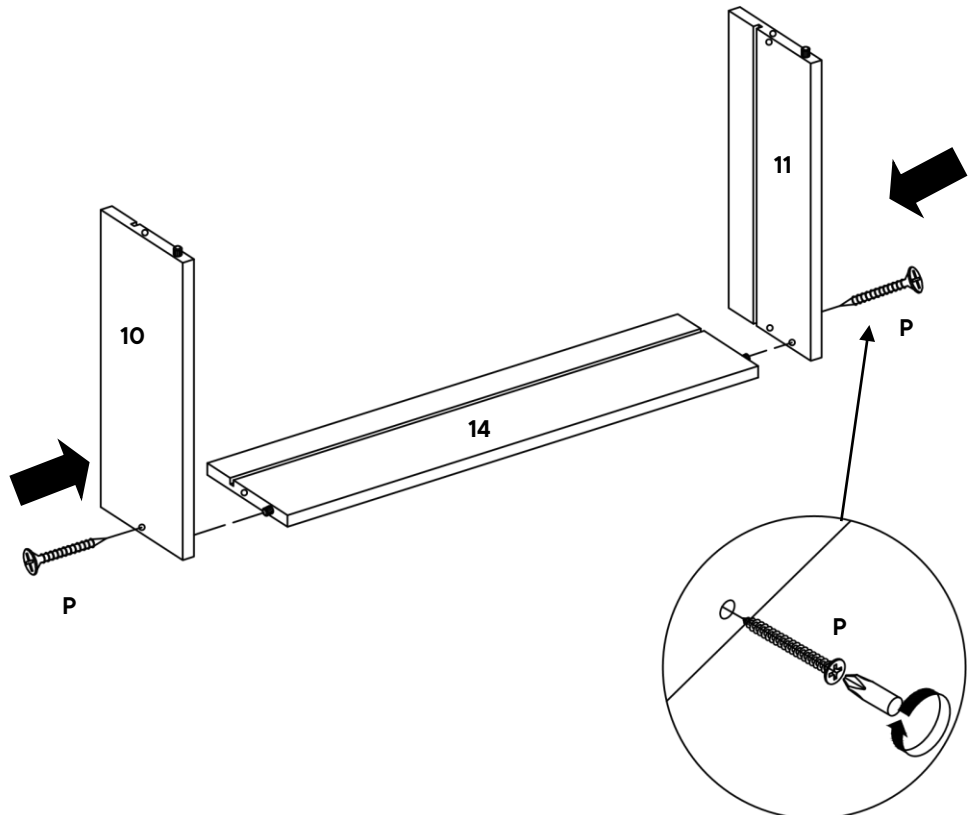

Step 15

HARDWARE

L Cam Lock- Ø12 x 9.9mm x2

COMPONENTS

10 Drawer Right x1

11 Drawer Left x1

12 Drawer Head x1

13 Drawer Base x1

14 Drawer Back x1

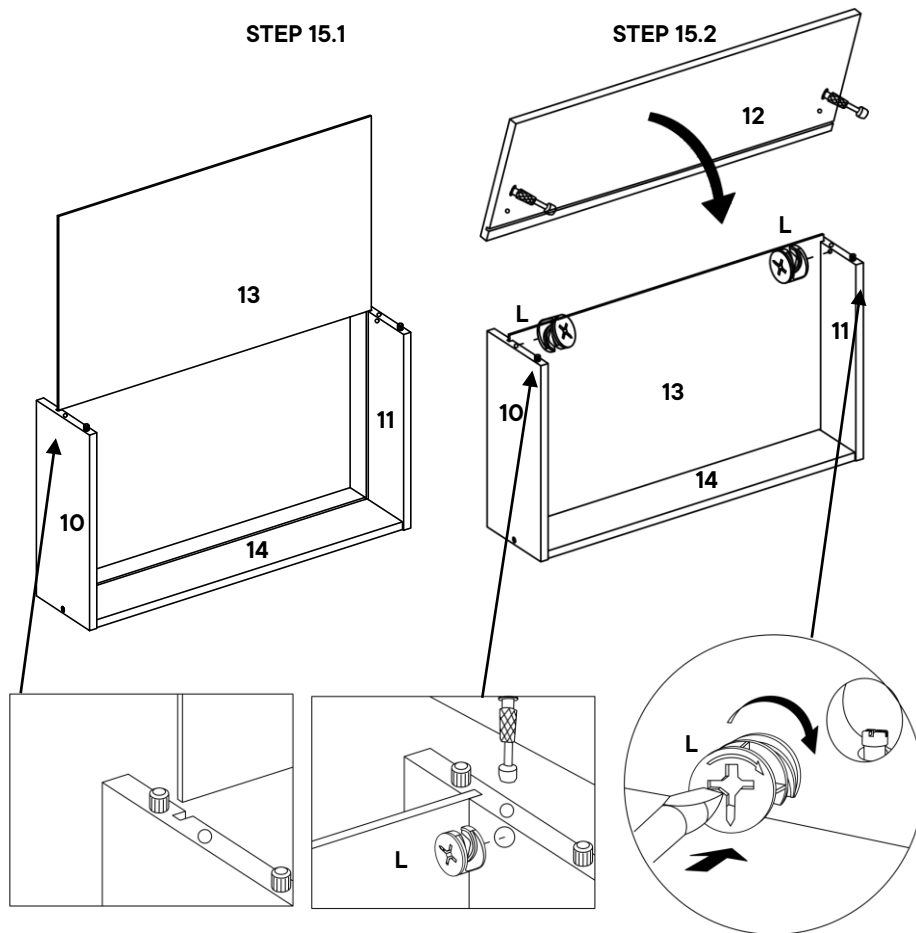

Step 16

HARDWARE

F C/board Screw Ø3.5 x 16mm x6

I Drawer Runner Left x1

J Drawer Runner Right x1

COMPONENTS

10 Drawer Right x1

11 Drawer Left x1

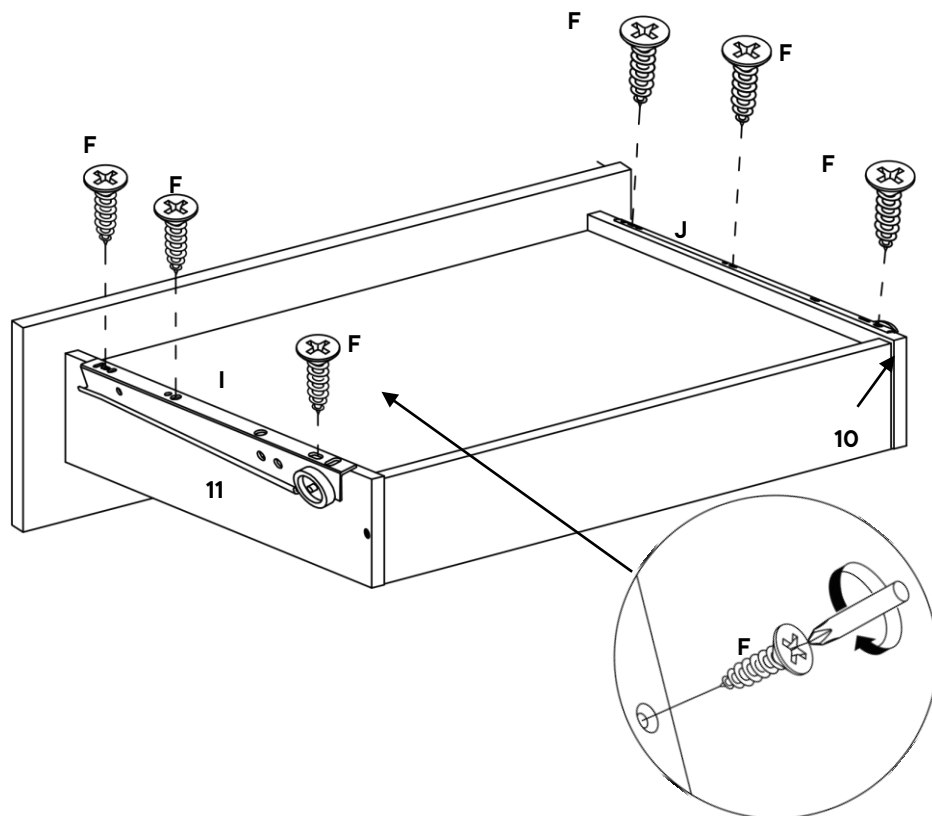

Step 17

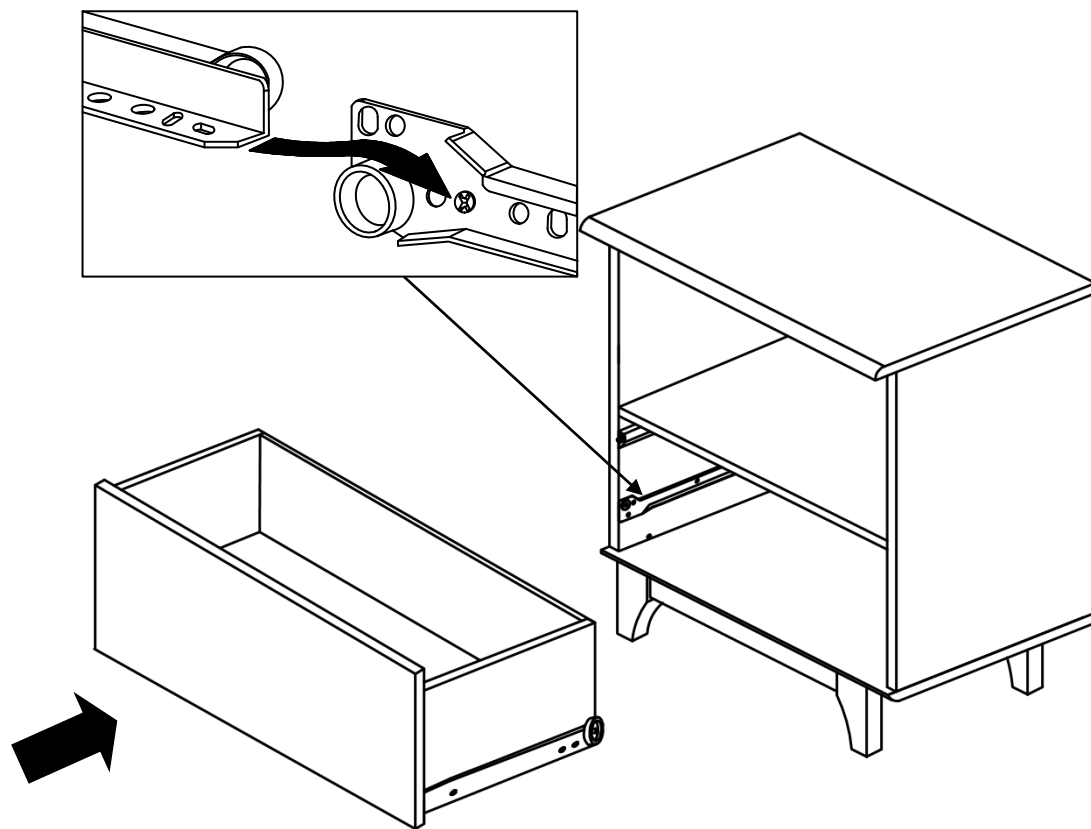

Great job!

Nightstand assembly is complete.

♥ CARING FOR YOUR ITEM

Indoor use only.

Not contract grade.

Clean using a non-abrasive cloth and a mild cleaner.

Never use harsh chemicals, as they could damage the finish or integrity of the item.

CONNECT WITH US!

Tag us [@modway_furniture](#) and [#modway](#) for a chance to be featured.

