





Thank you for purchasing the **MODWAY DRESSER!**
 Before you start, here is some helpful advice:



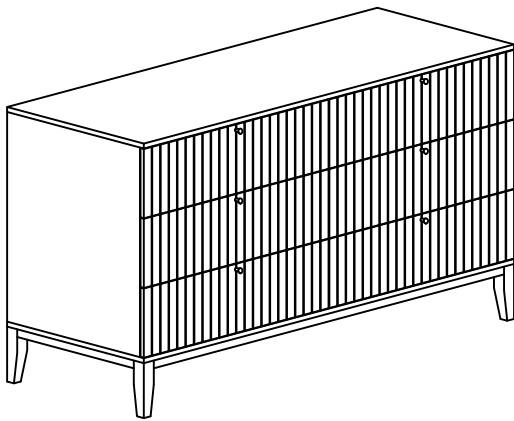

1. We suggest you spend a short time reading through this leaflet and then follow the simple step by step instructions.
2. Owing to the size and weight of the dresser, we recommend that it is assembled by two adults, on a carpeted or padded area, in the room that it is intended for. Approximate assembly time: 30 minutes.
3. Please do not use any tools other than those provided or recommended in these instructions.
4. Please do not throw away any of the packaging or the instruction until you have checked all the components and hardware and the furniture is fully assembled. Please ensure that the packaging is disposed of in a safe and environmentally friendly way.
5. Assemble all components loosely until advised to tighten. Depending on use, it may be necessary to tighten the components from time to time, so please save the tools that has been provided.
6. Please keep all fitting out of reach of children.

Hardware for Dresser

- | | | | |
|----------|--------------------------------|--|-----------|
| A | JCBC SCREW M6 x 60MM |  | x8 |
| B | SPRING WASHER 1/4" |  | x8 |
| C | FLAT WASHER 1/4" |  | x8 |
| D | M4 ALLEN KEY (BALL SHAPE) LONG |  | x1 |
| E | FELT PROTECTOR |  | x4 |



Anti Tipping Hardware

- | | | | |
|----------|----------------------|---|-----------|
| F | WALL SCREW M4 x 18MM |  | x1 |
| G | WALL SCREW M4 x 50MM |  | x1 |
| H | L-BRACKET |  | x2 |
| K | BELT |  | x1 |

Component :

- 1- DRESSER
- 2- DRESSER LEGS

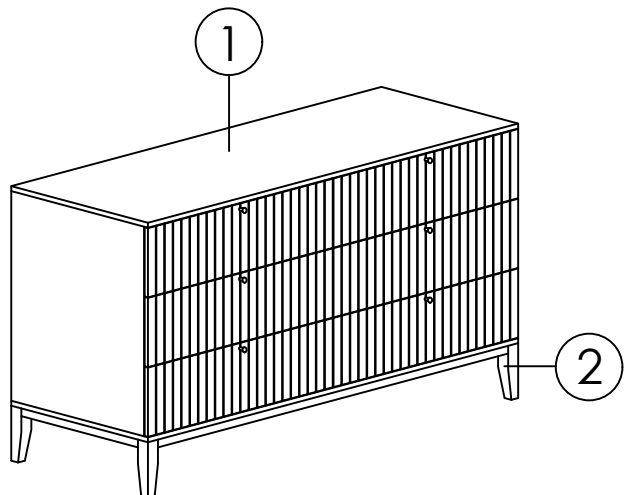

STEP 1:

Place **Dresser (1)** on a carpeted surface. Attach **Dresser Legs (2)** to the **Dresser (1)** by inserting **JCBC Screw M6x60mm (A)**, **Spring Washer 1/4" (B)** and **Flat Washer 1/4" (C)**. Tighten with **M4 Allen Key (D)**. At last, put the **Felt Protector (E)** on the soles of **Dresser (1)** as shown in the picture.

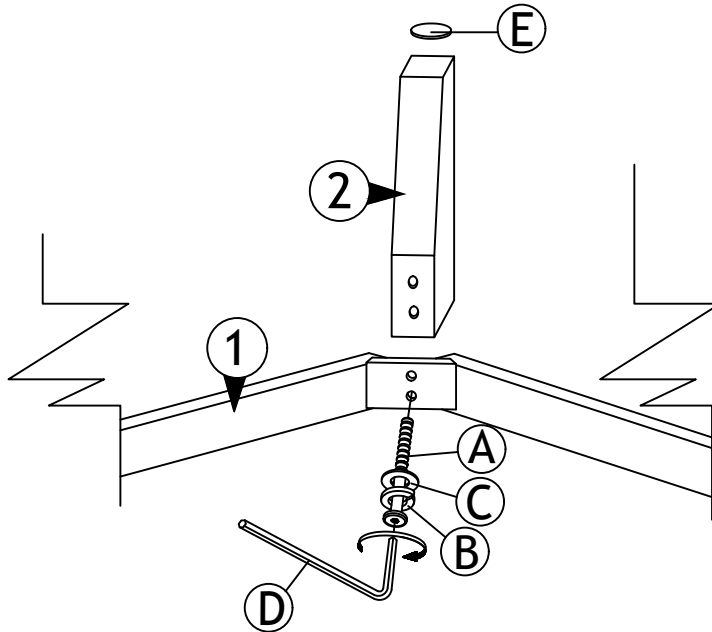

A x 8	B x 8	C x 8	D x 1	E x 4

Hardware & Tool required

STEP 2:

Attach one of the **L-Bracket (H)** to the wall by inserting **Wall Screw M4x50mm (G)**. Then attach another **L-Bracket (H)** to the backside center of the **Dresser (1)** by inserting **Wall Screw M4x18mm (F)**.

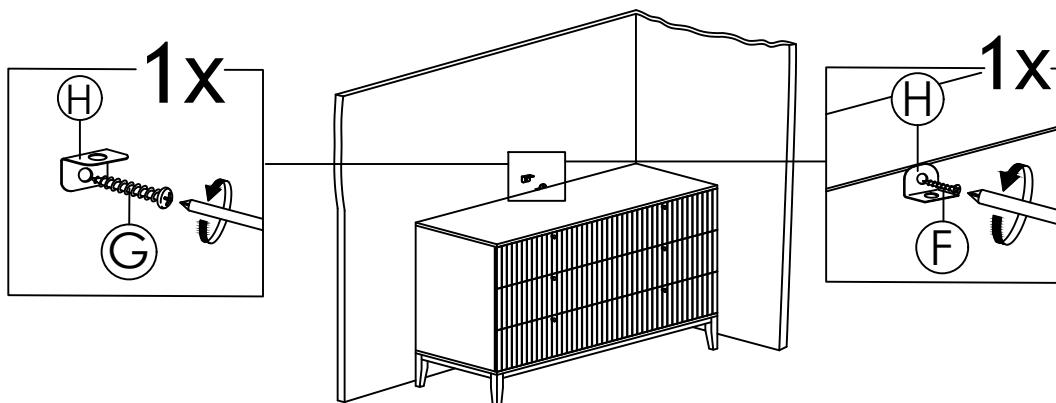

F x 1	G x 1	H x 2

Hardware & Tool required

STEP 3:

Attach the two **L-Bracket (H)** with the **Belt (K)**.

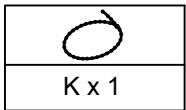
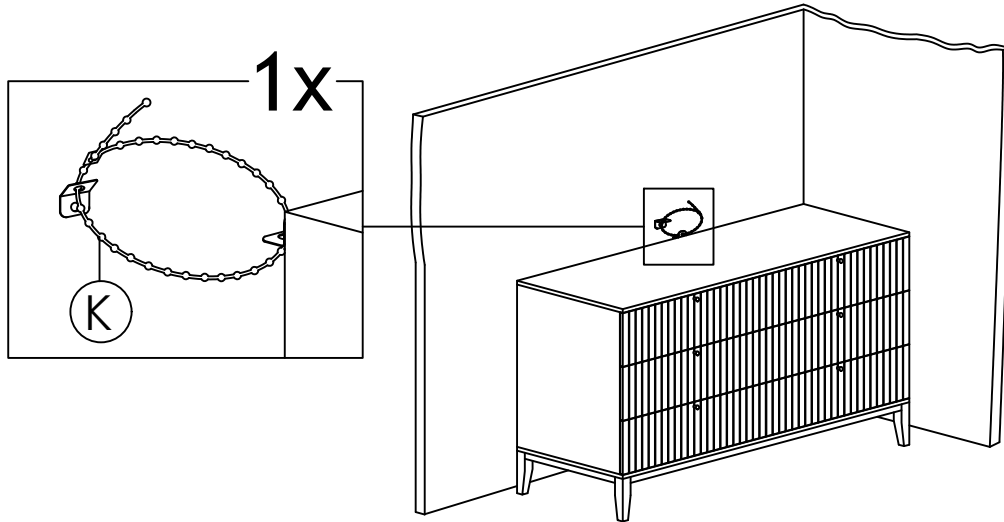

Hardware & Tool required

STEP 4:

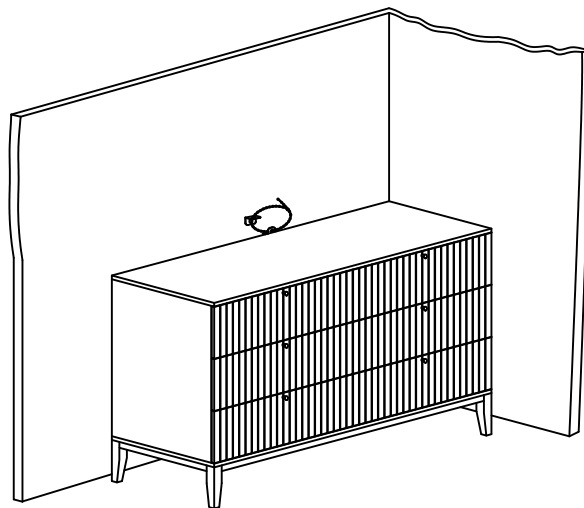

Assembly is complete. The Dresser is ready to be enjoyed now!

Hardware & Tool required