

MOD-6239

Thank you for purchasing the **MODWAY BED!**

Before you start, here are some helpful advice:

1. We suggest you spend a short time reading through this leaflet and then follow the simple step instructions.
2. Owing to the size and weight of the bed, we recommend that it is assembled by two adults, on a carpeted or padded area, in the room that it is intended for. Approx assembly time: 40 minutes.
3. Please do not use any tools other than those provided or recommended in these instructions.
4. Please do not throw away any of the packaging or the instruction until you have checked all the components and hardware and the furniture is fully assembled. Please ensure that the packaging is disposed of in a safe environmentally friendly way.
5. Assemble all components loosely until advised to tighten. Depending on use, it may be necessary to tighten the components from time to time, so please save tools that have been provided.
6. Please keep all fitting out of reach of children.





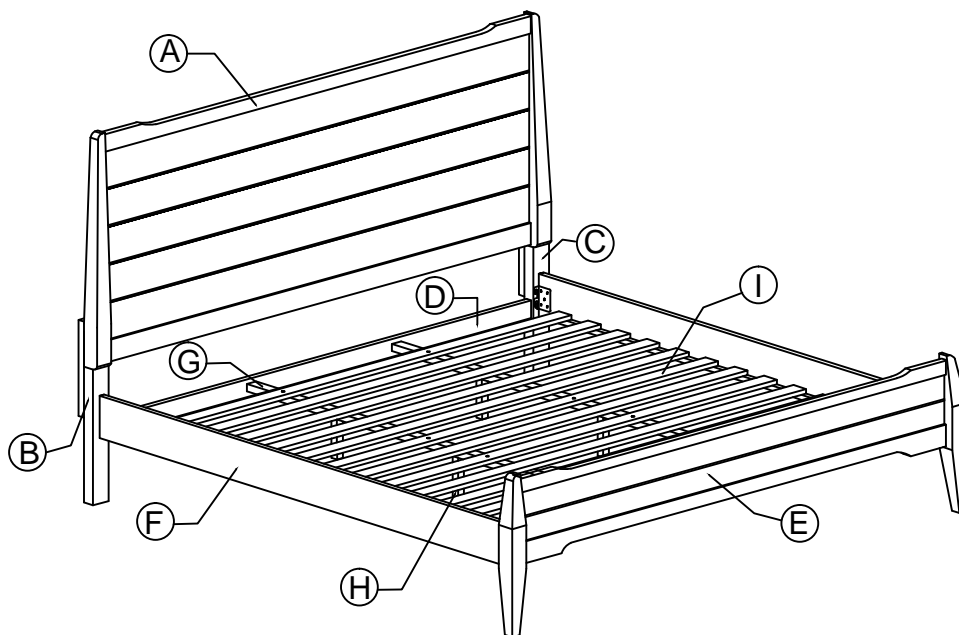





Components:

A	HEADBOARD PANEL	1 PC	F	SIDE RAIL	2 PCS
B	HEADBOARD LEG (L)	1 PC	G	CENTER RAIL	2 PCS
C	HEADBOARD LEG (R)	1 PC	H	CENTER RAIL LEG	6 PCS
D	HEADBOARD SUPPORT RAIL	1 PC	I	BED SLATS	1 SET
E	FOOTBOARD PANEL	1 PC			

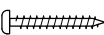

MOD-6239

HARDWARE BED FRAME

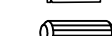
1		JCBC BOLT M6 x 90mm	8 PCS	8		M6 SPRING WASHER	14 PCS
2		JCBC BOLT M6 x 50mm	6 PCS	9		M6 FLAT WASHER	14 PCS
3		JCBC BOLT M6 x 40mm	16 PCS	10		PH SCREW M4 x 32mm	18 PCS
4		JCBC BOLT M6 x 20mm	8 PCS	11		M4 ALLEN KEY	1 PC
5		JCBC BOLT M6 x 15mm	8 PCS	12		L BRACKET	4 PCS
6		BARREL NUT	6 PCS	13		ADJUSTABLE FOOT	6 PCS
7		WOOD DOWEL M10 x 40MM	2 PCS				

STEP 1

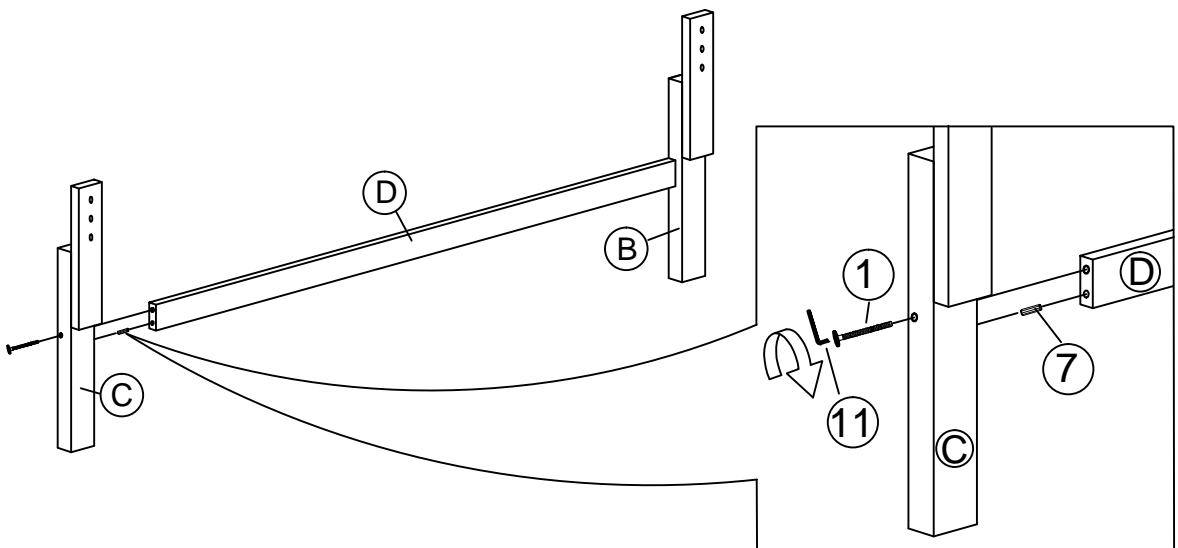

STEP 2

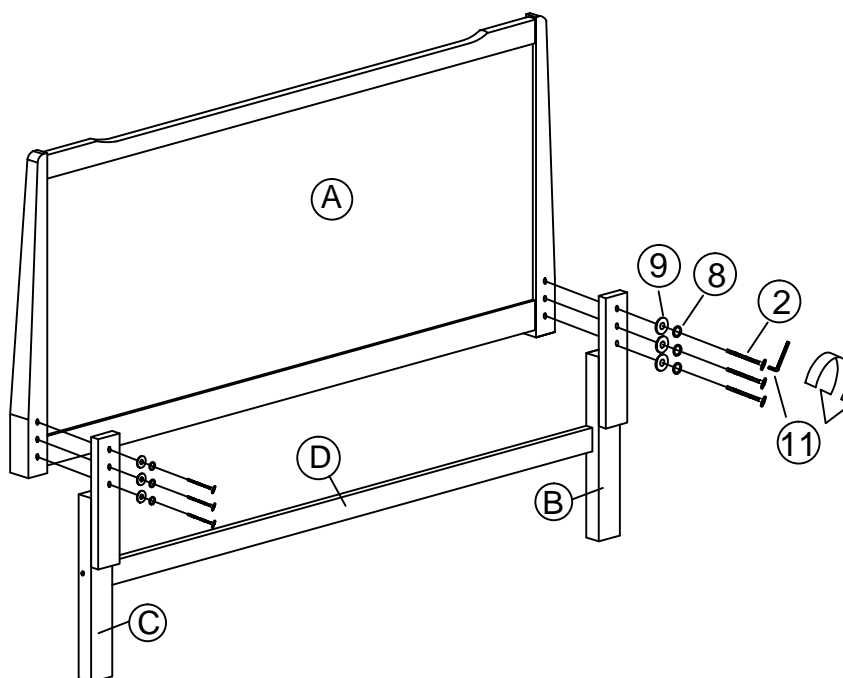

MOD-6239

STEP 3

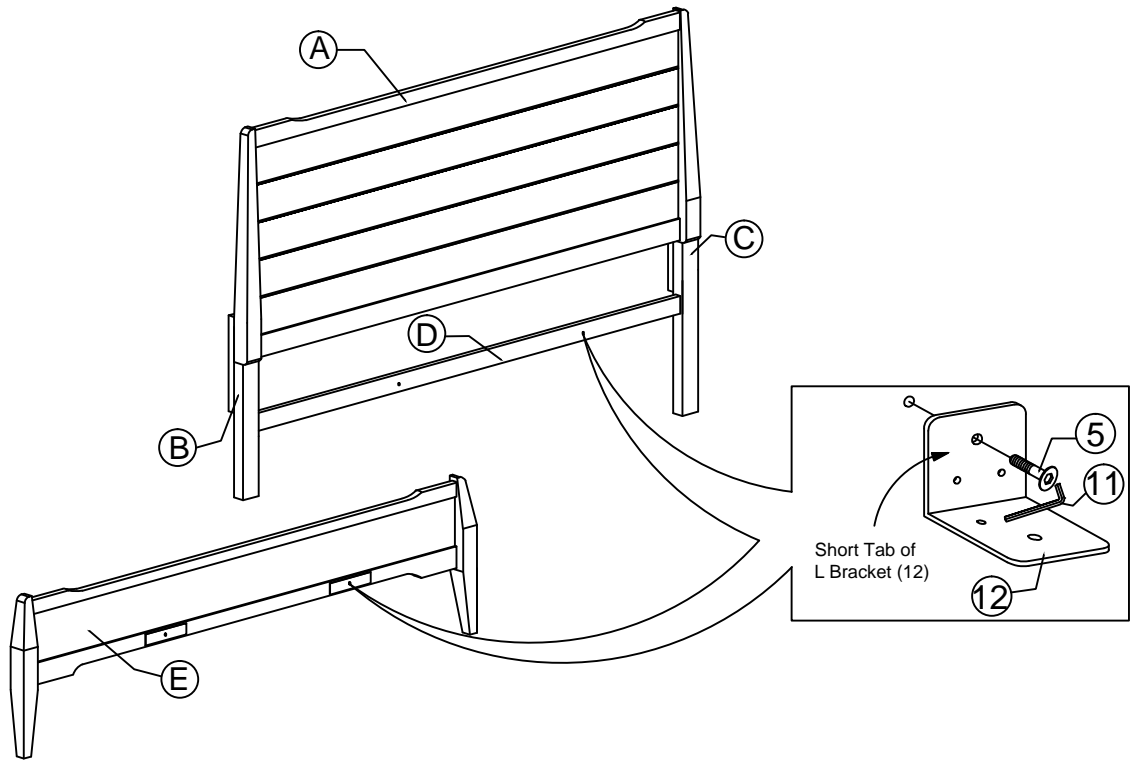

STEP 4

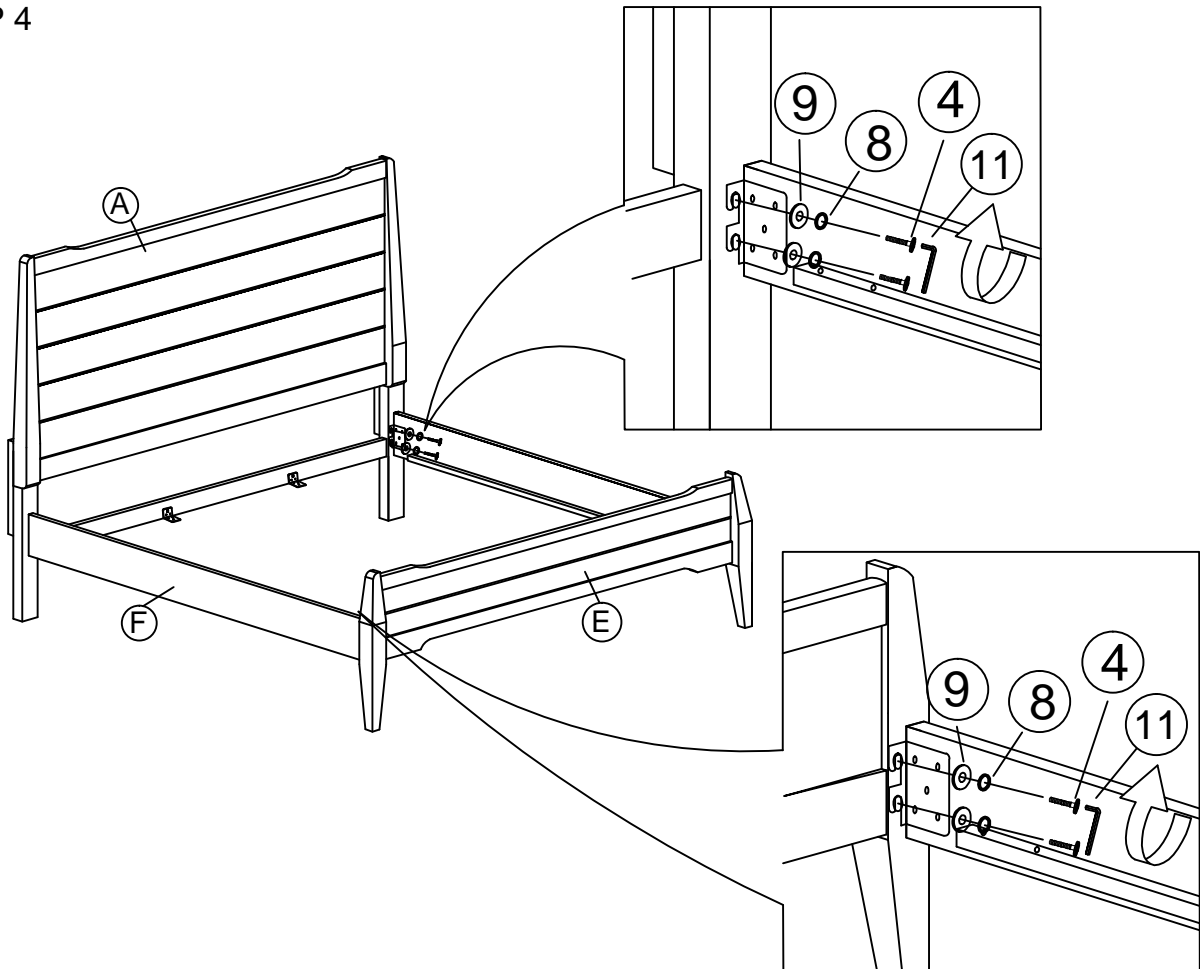

MOD-6239

STEP 5

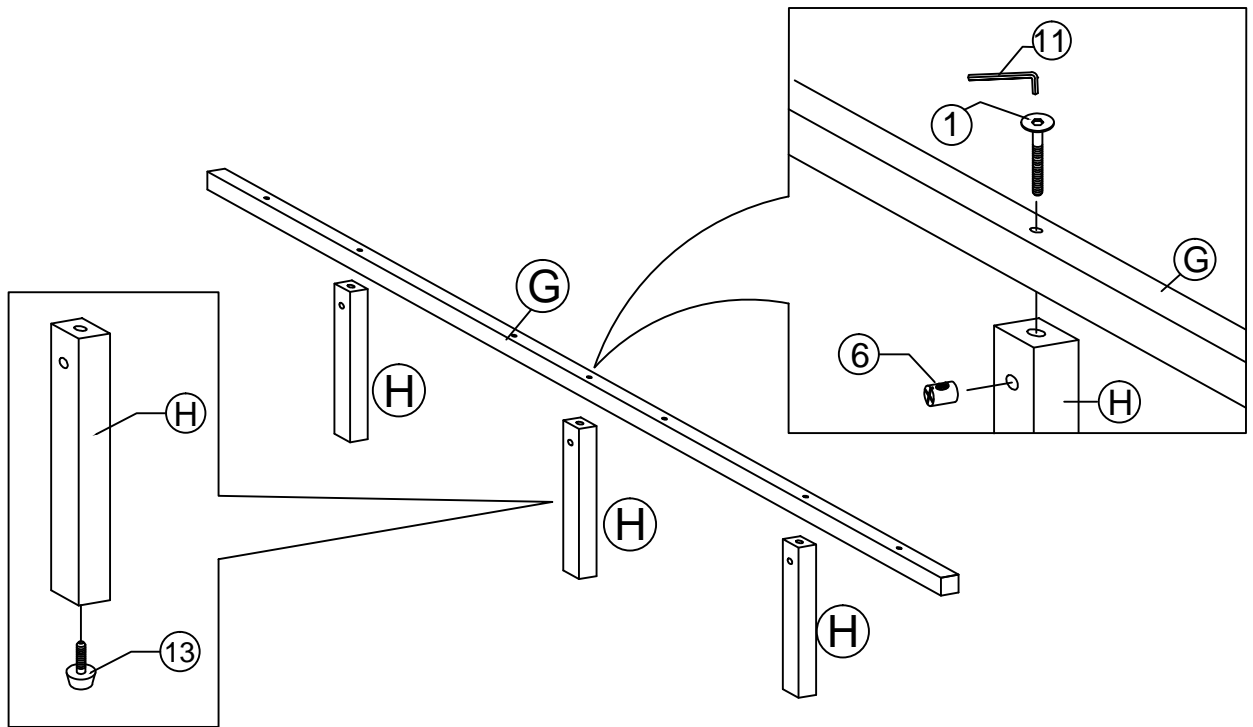

STEP 6

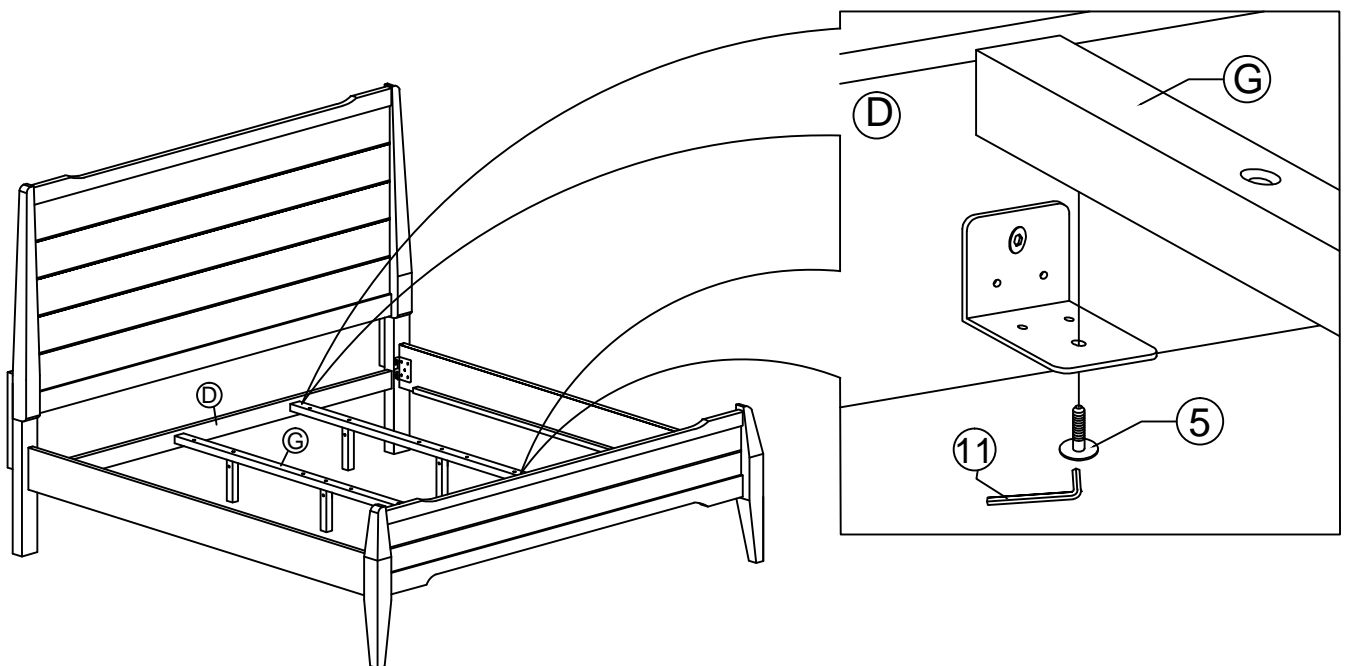

STEP 7

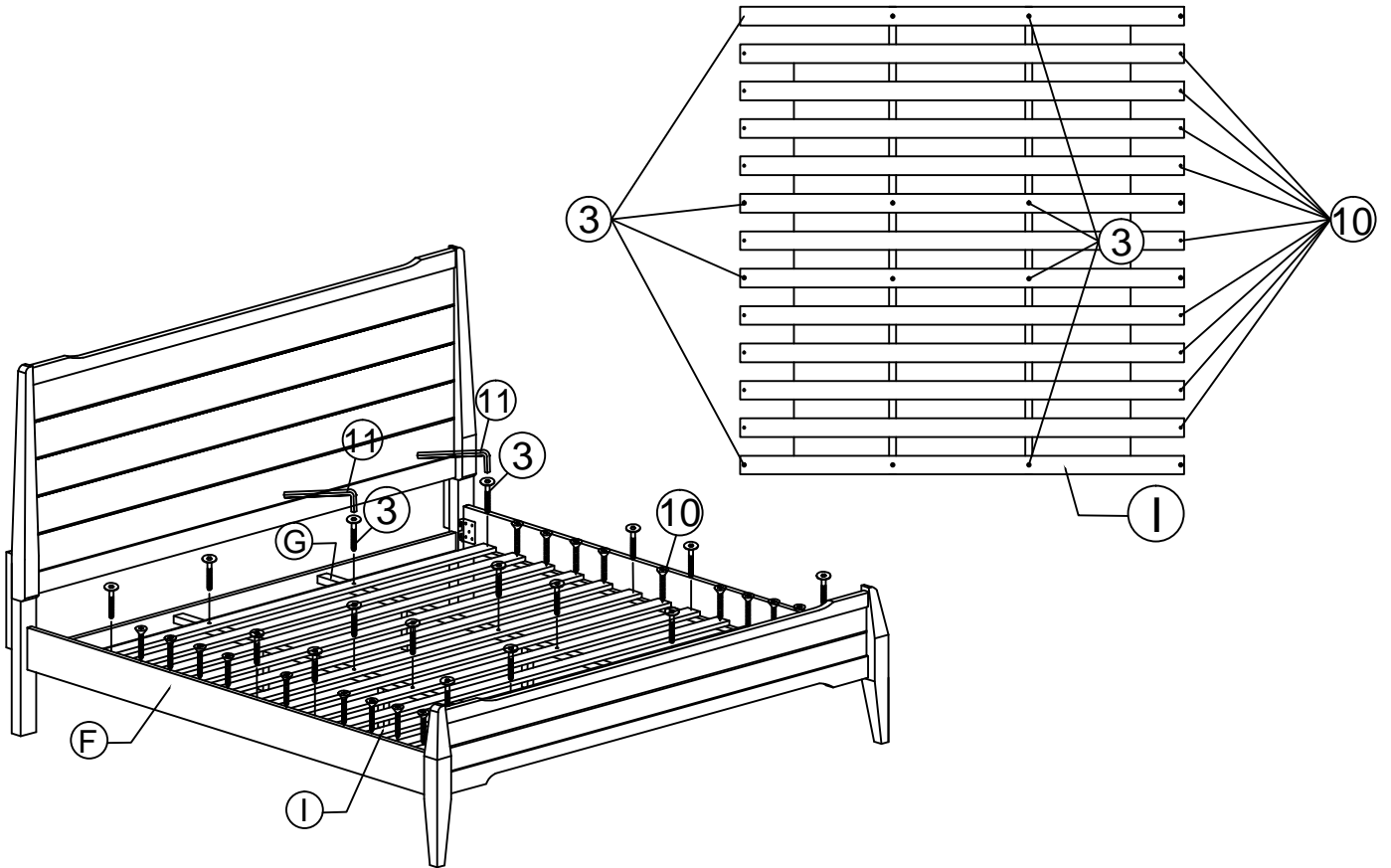

STEP 8

8.1 Assembly completed.

