











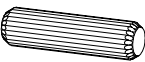

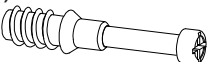

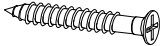
Thank you for purchasing the **MODWAY CHEST OF DRAWERS!**

Before you start, here are some helpful advice:

1. We suggest you spend a short time reading through this leaflet and then follow the simple step-by-step instructions.
2. Owing to the size and weight of the chest of drawers, we recommend that it is assembled by two adults, on a carpeted or padded area, in the room that it is intended for. Approximate assembly time: 60 minutes.
3. Please do not use any tools other than those provided or recommended in these instructions.
4. Please do not throw away any of the packaging or instructions until you have checked all the components and hardware and the furniture is fully assembled.
5. Assemble all components loosely until advised to tighten. Depending on use, it may be necessary to tighten the components from time to time, so please save the tools that have been provided.
6. Please keep all pieces out of reach of children.

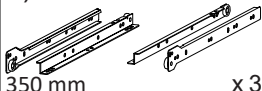
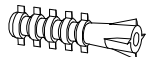

Hardware :

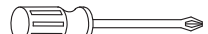
A) Dowel Big/Wood  \varnothing 8 x 30 mm x 34	B) Dowel Small/Wood  \varnothing 6 x 30 mm x 12	C) Cambolt/Metal  \varnothing 6 x 35 mm x 26	D) Screw/Metal  M 12 x 45 mm x 4	E) Screw/Metal  M 8 x 39 mm x 12
F) Screw/Metal  M 12 x 35 mm x 6	G) Cable Ties / Plastic  x 2	H) Screw/Metal  M 3.5 x 15.5 mm x 12	I) Screw/Metal  M 3.5 x 13 mm x 18	J) Screw/Metal  M 6.5 x 10.5 mm x 12
K) CamLock Big/Metal  \varnothing 15 mm x 14	L) CamLock Small/Metal  \varnothing 12 mm x 12	M) Wedge/Plastic  9 x 14 x 10 mm x 8	N) Rail/Metal  350 mm x 3	O) Fisher/Plastic  5003 x 4
P) Screw/Metal  M 3.5 x 32 mm x 4	Q) x 1  Screwdriver (Not Include)			

Components:

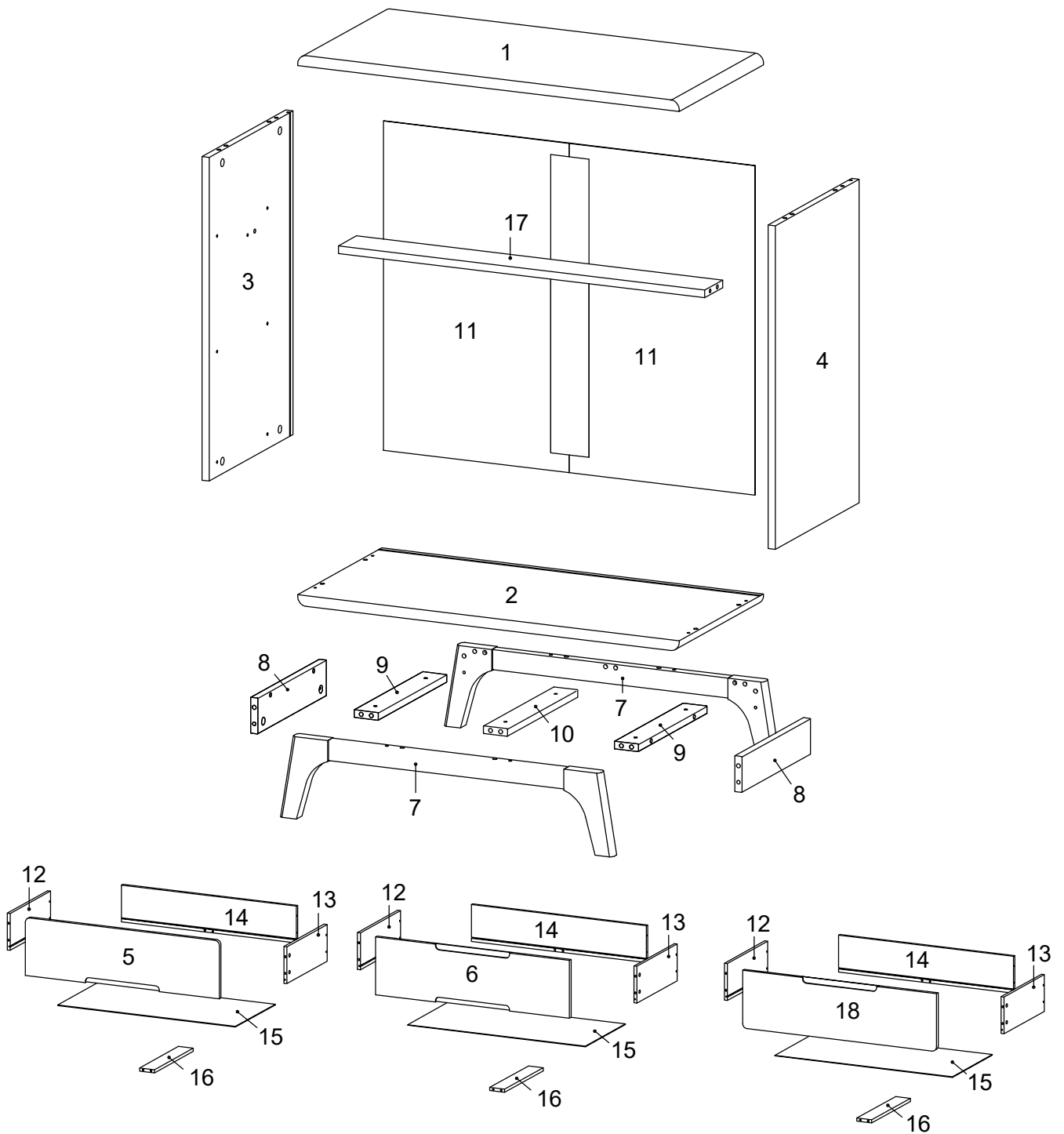

1	Top Board	x1	2	Bottom Board	x1	3	Side Board Left	x1	4	Side Board Right	x1
5	Front Drawer Upper	x1	6	Front Drawer Middle	x1	7	Leg	x2	8	Support Board 1	x2
9	Support Board 2	x2	10	Support Board 3	x1	11	Back Board	x2	12	Side Drawer Left	x3
13	Side Drawer Right	x3	14	Back Drawer	x3	15	Bottom Drawer	x3	16	Support Drawer	x3
17	Support Board 5	x1	18	Front Drawer Bottom	x1						

STEP 1:

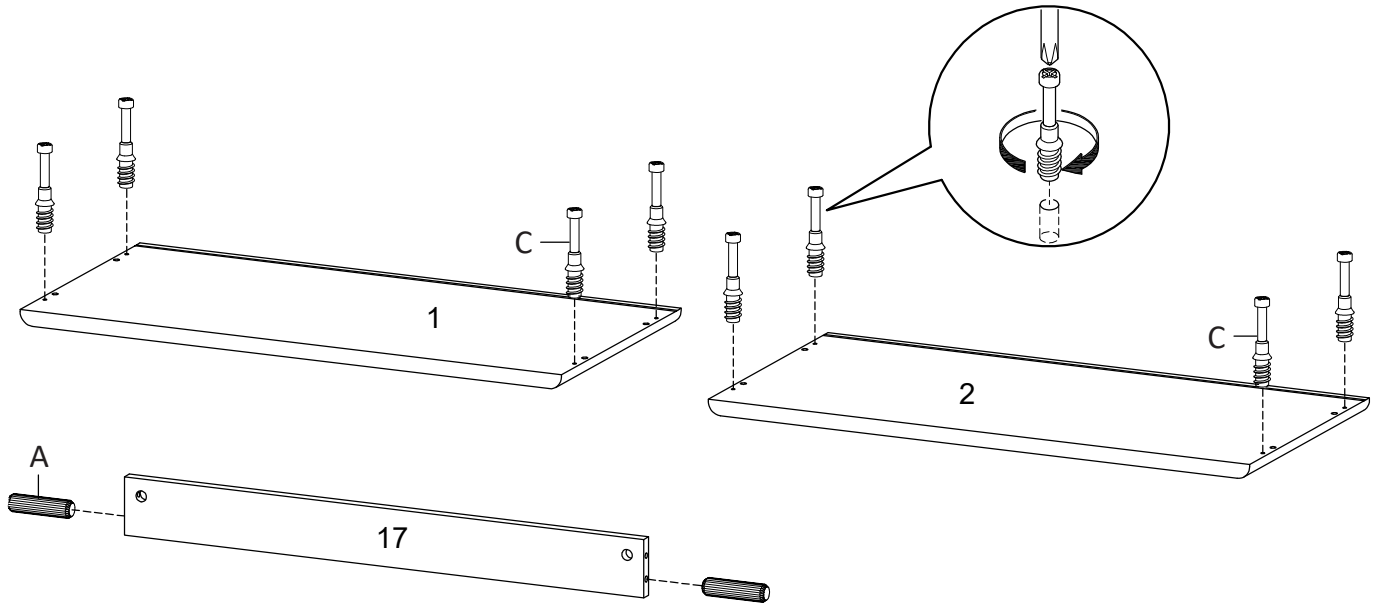

Ax2	Cx8	Qx1

Hardware required. Screwdriver not included

STEP 2:

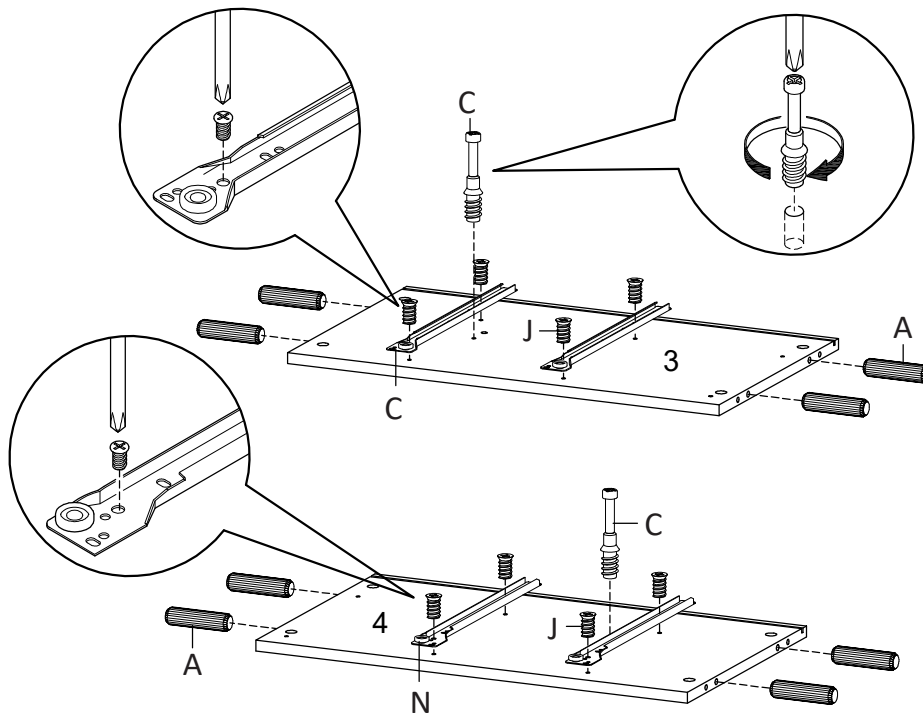

Ax8	Cx2	Jx8	Nx2	Qx1

Hardware required.
Screwdriver not included

STEP 3:

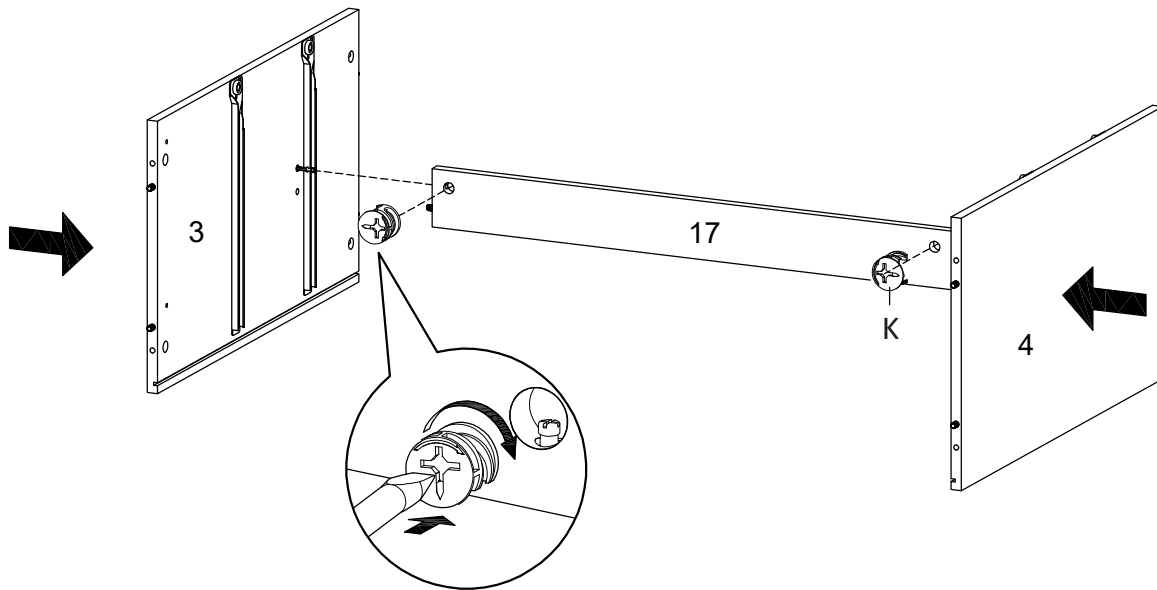

Kx2	Qx1

Hardware required. Screwdriver not included

STEP 4:

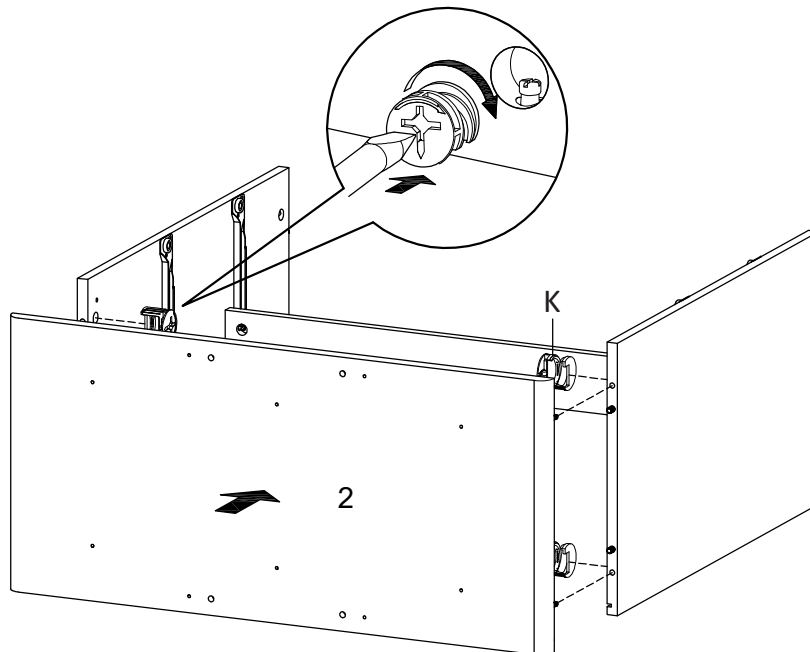

Kx4	Qx1

Hardware required. Screwdriver not included

STEP 5:

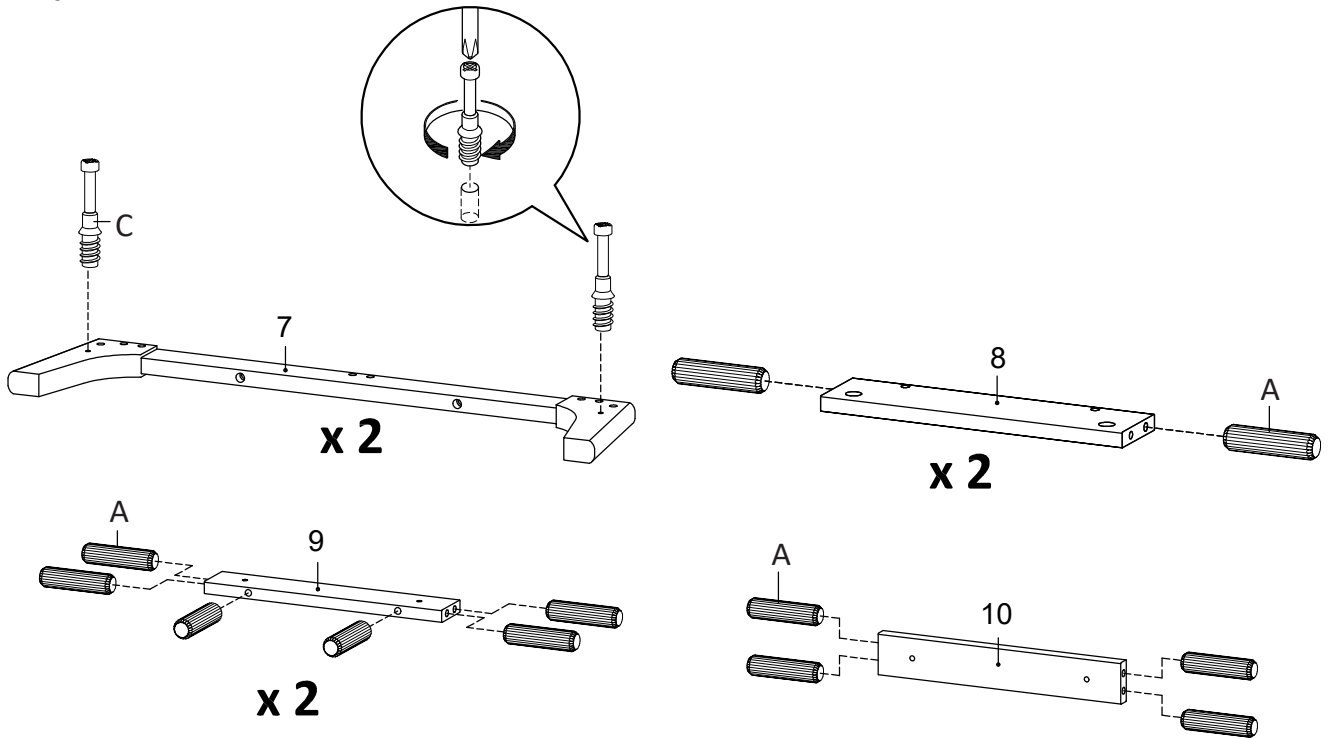

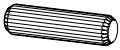
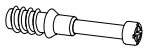
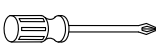
		
Ax20	Cx4	Qx1

Hardware required. Screwdriver not included

STEP 6:

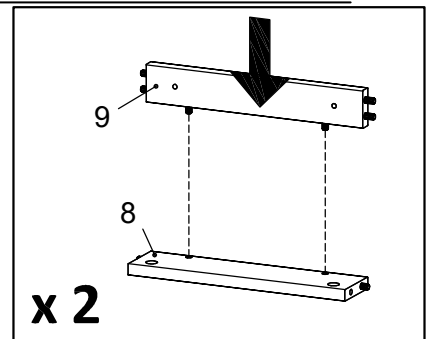
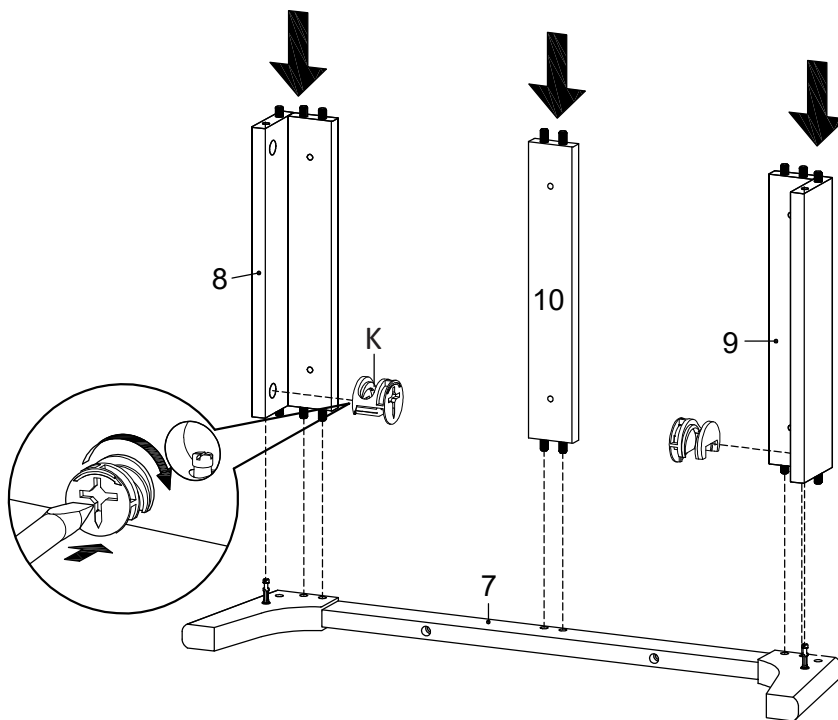

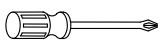
	
Kx2	Qx1

Hardware required. Screwdriver not included

STEP 7:

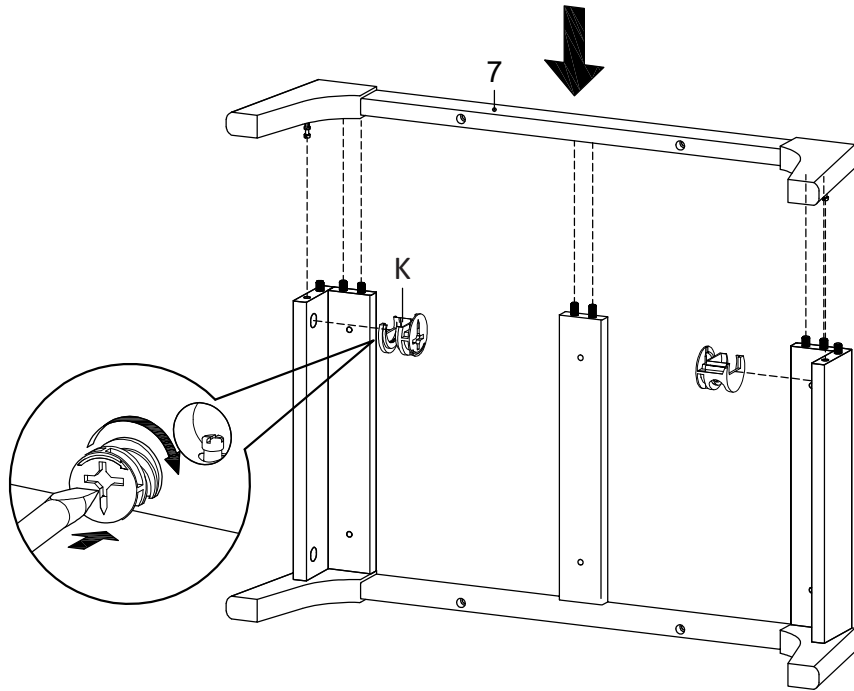

Kx2	Qx1

Hardware required. Screwdriver not included

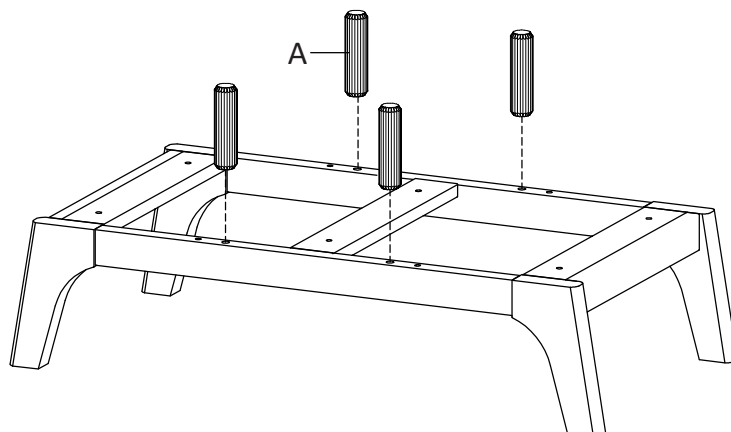

STEP 8:

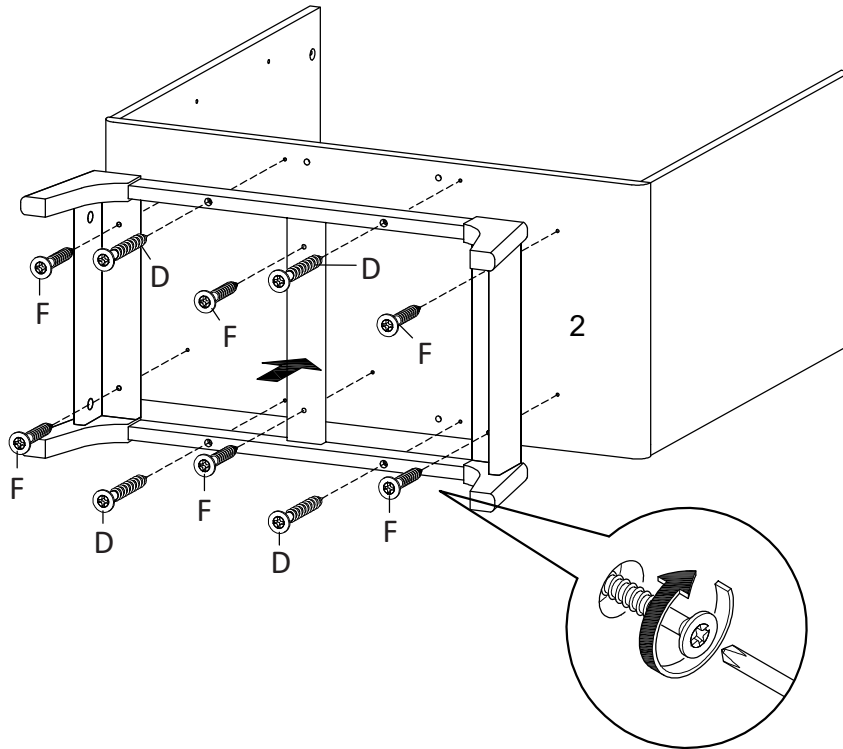

Ax4

STEP 9:

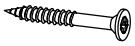

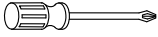
		
Dx4	Fx6	Qx1

Hardware required. Screwdriver not included

STEP 10:

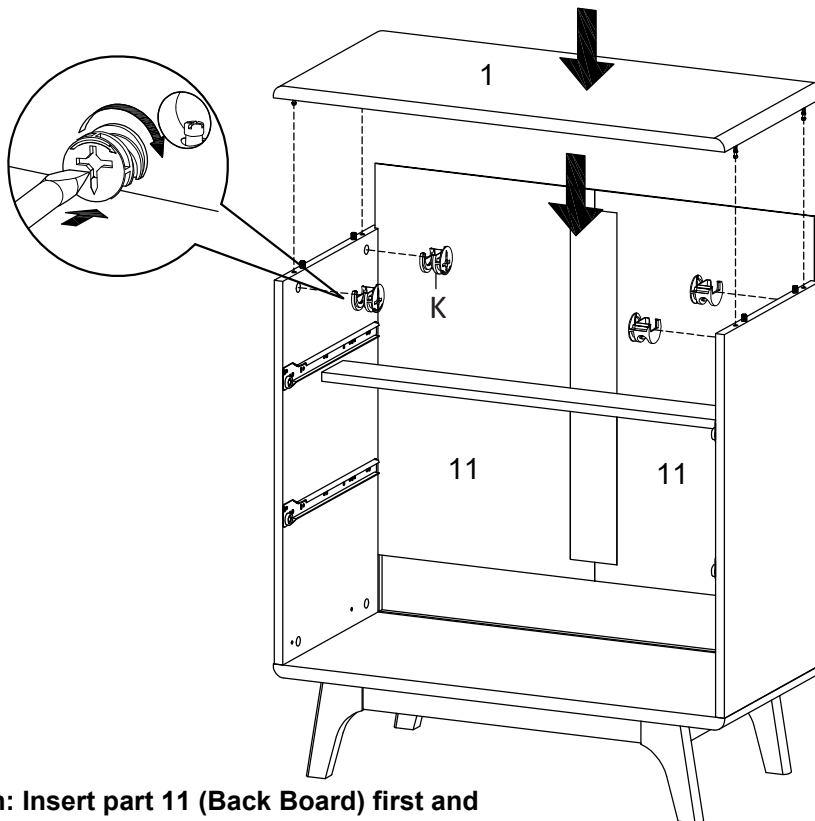

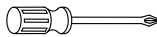

Attention: Insert part 11 (Back Board) first and then part 1 (Top Board)

	
Kx4	Qx1

Hardware required.
Screwdriver not included

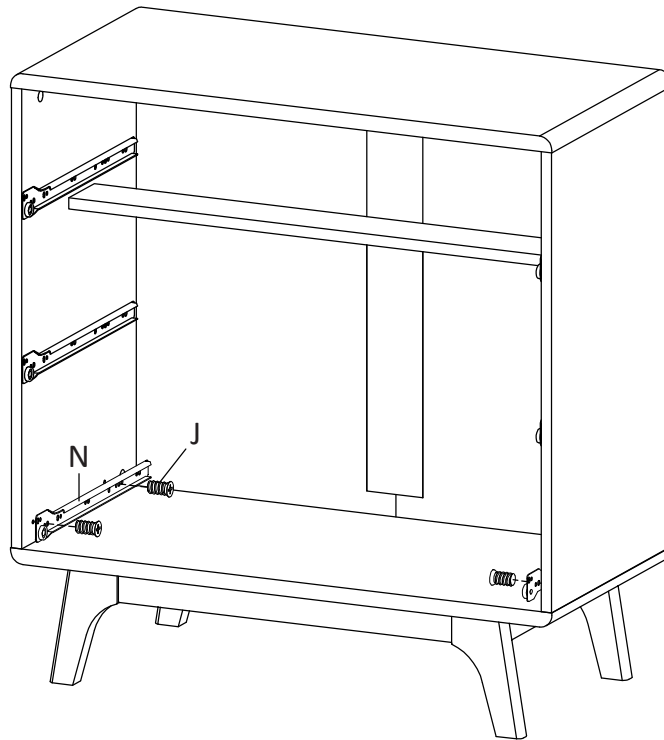
STEP 11:

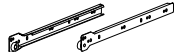

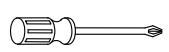

		
Nx1	Jx4	Qx1

Hardware required. Screwdriver not included

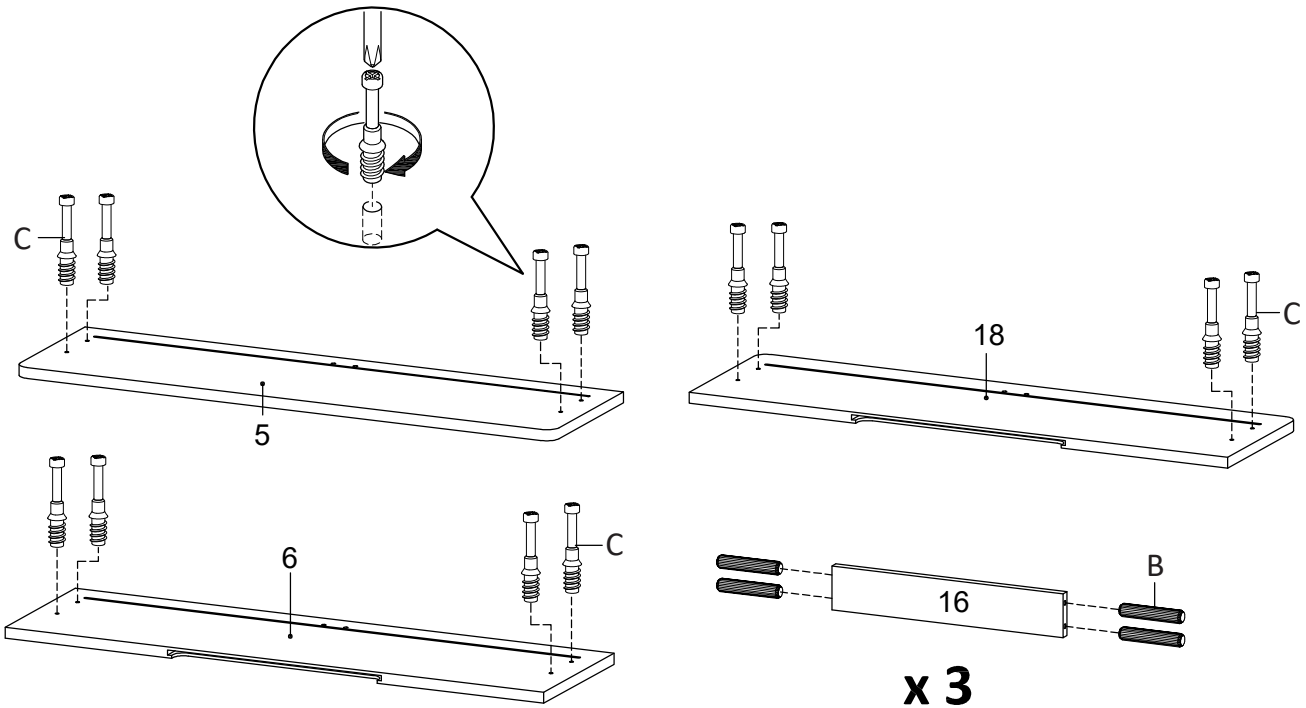
STEP 12:

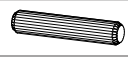
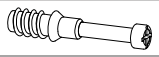

		
Bx12	Cx12	Qx1

Hardware required. Screwdriver not included

STEP 13:

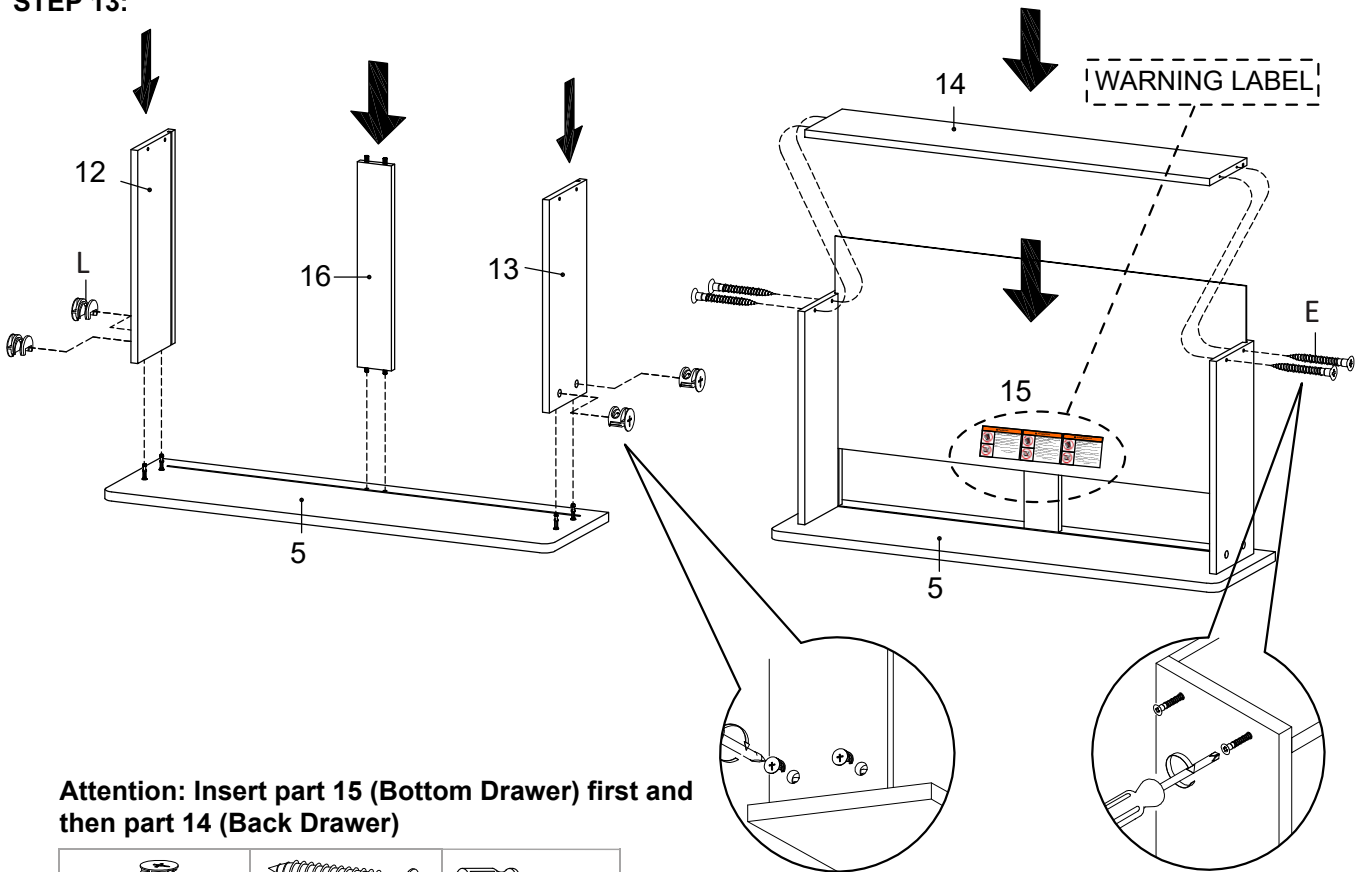

Attention: Insert part 15 (Bottom Drawer) first and then part 14 (Back Drawer)

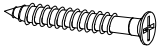
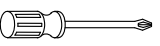
		
Lx4	Ex4	Qx1

Hardware required. Screwdriver not included

STEP 14:

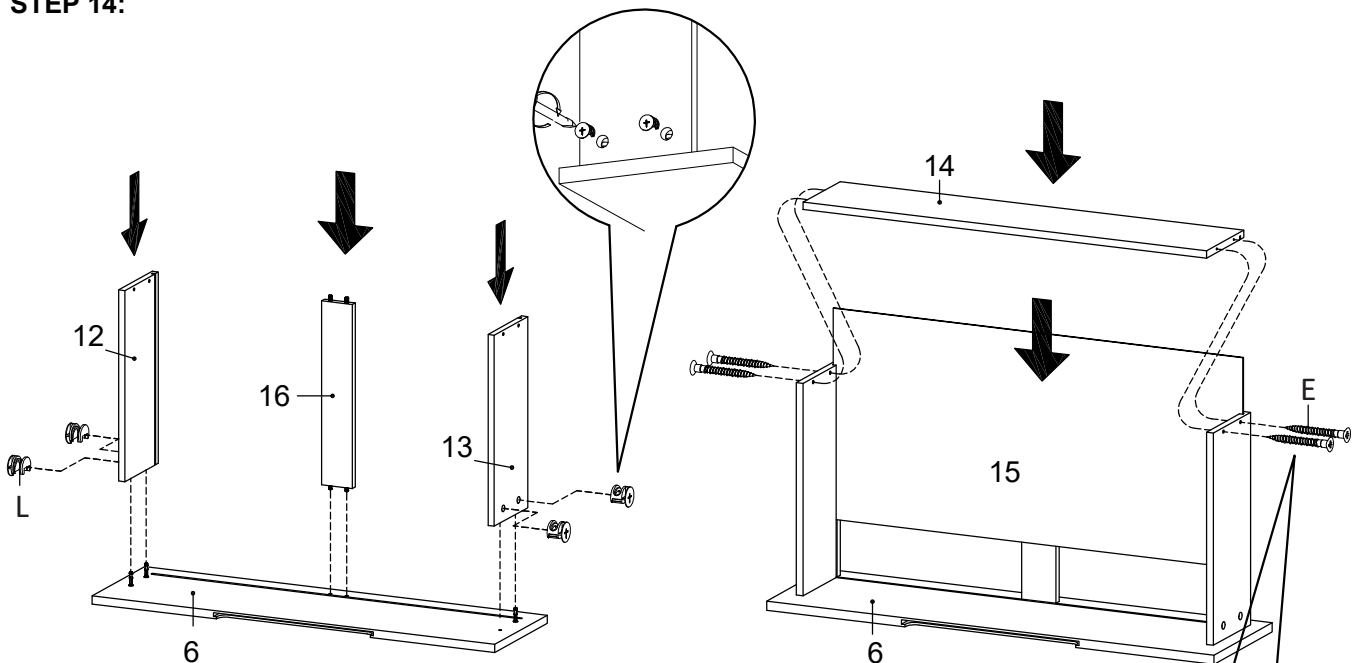

Attention: Insert part 15 (Bottom Drawer) first and then part 14 (Back Drawer)

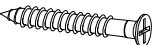
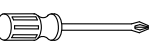
		
Lx4	Ex4	Qx1

Hardware required. Screwdriver not included

STEP 15:

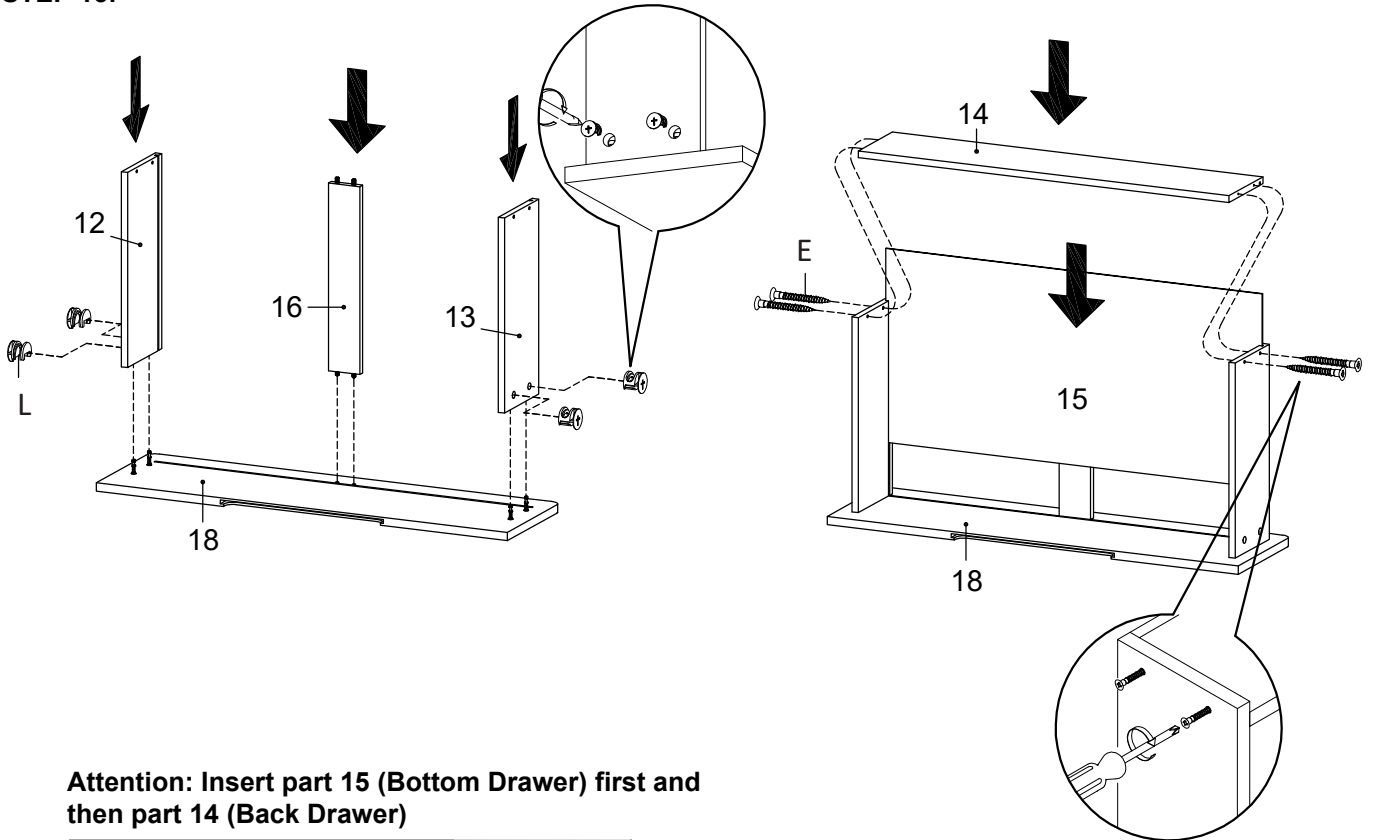

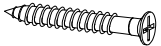
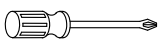

Attention: Insert part 15 (Bottom Drawer) first and then part 14 (Back Drawer)

		
Lx4	Ex4	Qx1

Hardware required. Screwdriver not included

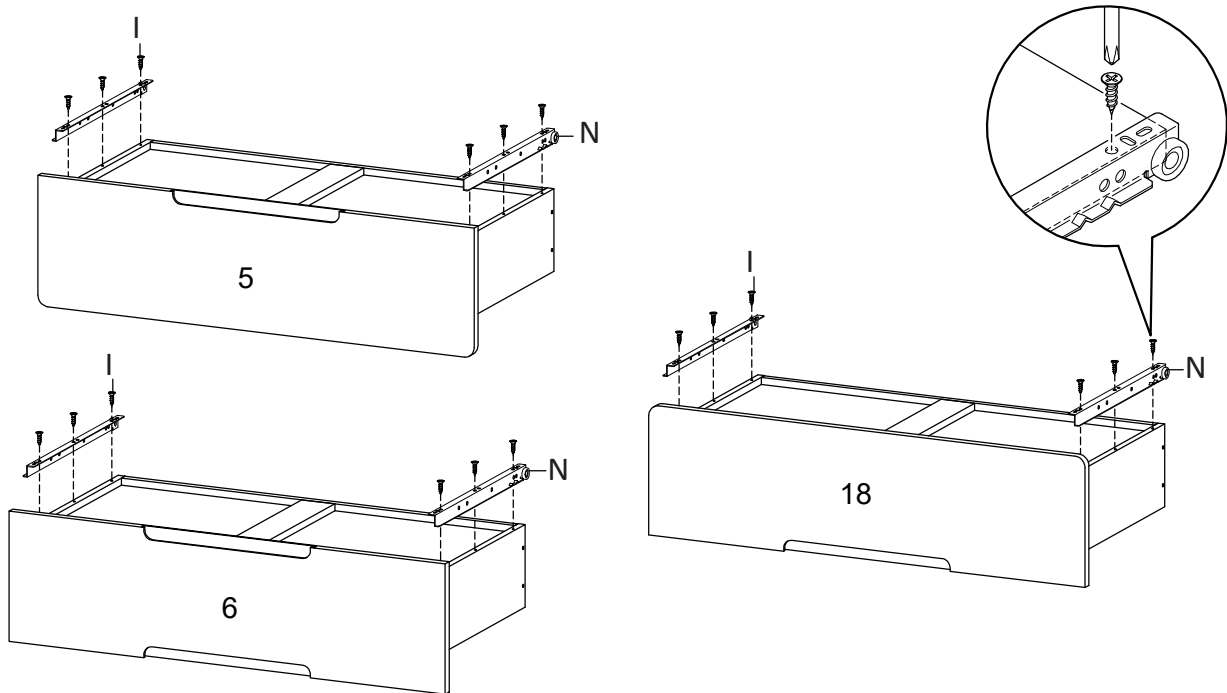
STEP 16:

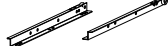

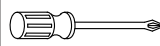
		
Nx3	Ix18	Qx1

Hardware required. Screwdriver not included

STEP 17:

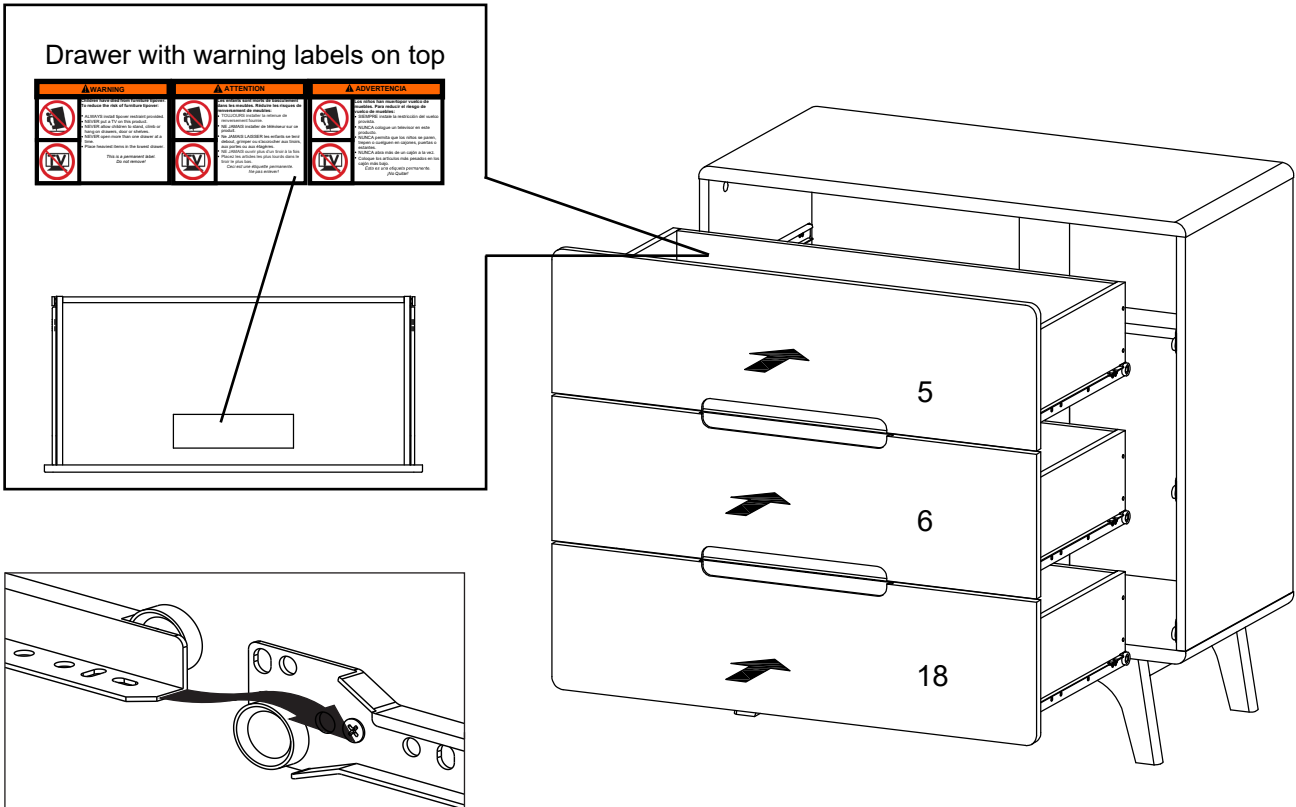

STEP 18:

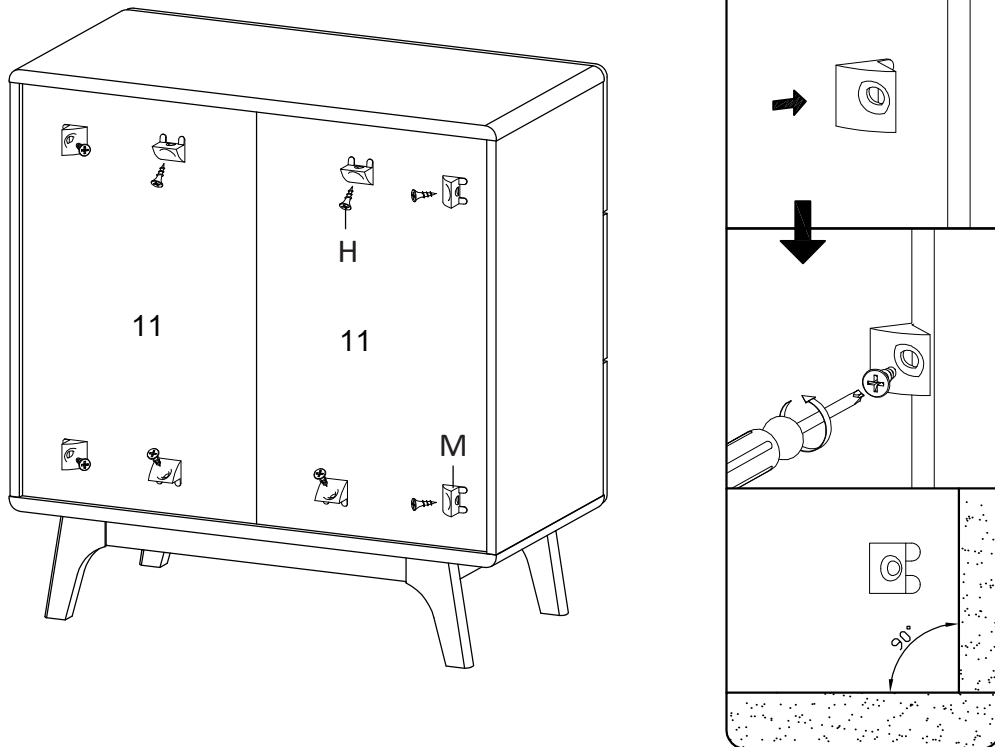

Mx8	Hx8	Qx1

Hardware required. Screwdriver not included

STEP 19: Anti Tipping Kit Installation

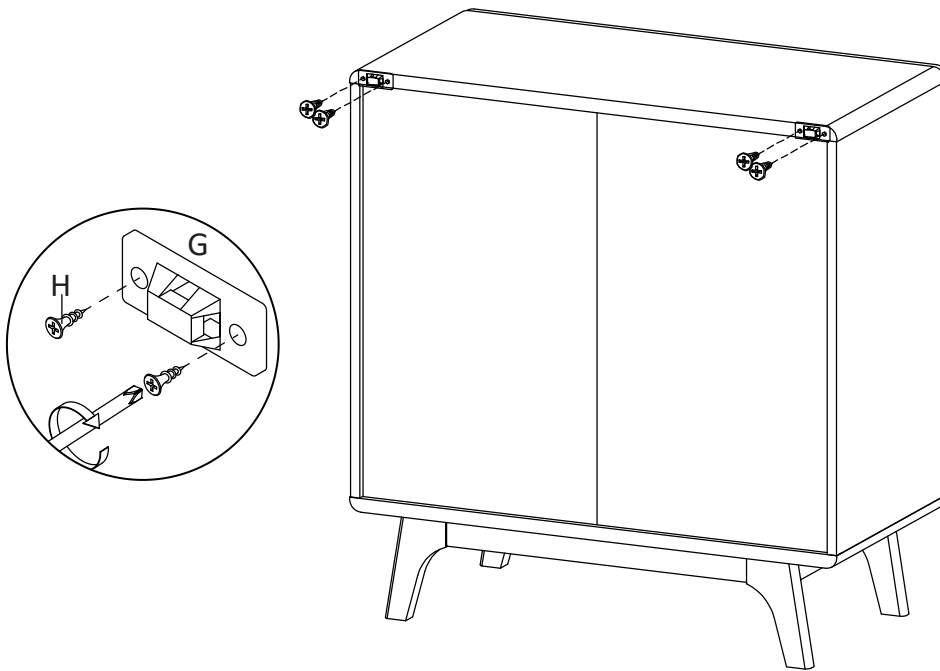

Gx2	Hx4	Qx1

Hardware required.
Screwdriver not included

STEP 20: Anti Tipping Kit Installation

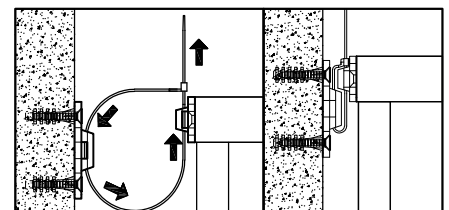
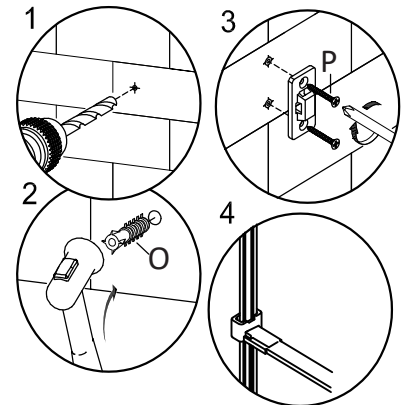
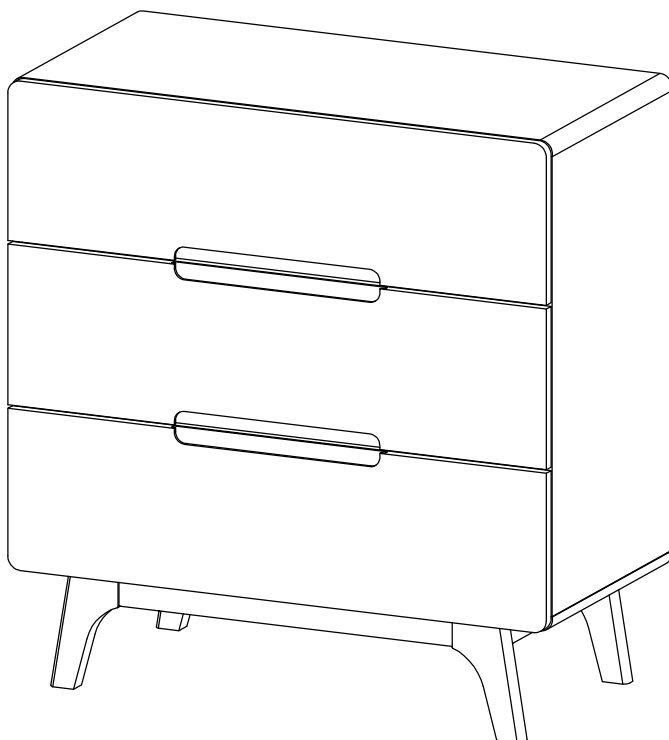

Ox4	Px4	Qx1

Hardware required. Screwdriver not included

STEP 21:



Assembly is complete. The Chest of Drawers is ready to enjoy now!