

# EEI-4222 RIGHT ARM LOVESEAT

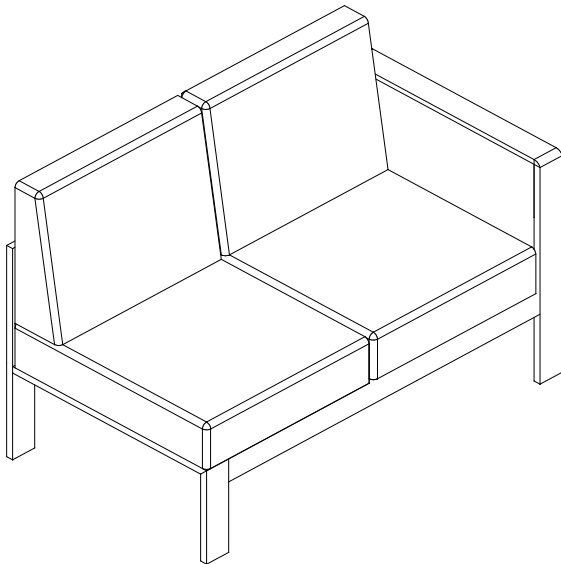

Thank you for purchasing the **MODWAY RIGHT ARM LOVESEAT**.

Before you start, here are some helpful advice:

1. We suggest you spend a short time reading through this leaflet and then follow the simple step-by-step instructions.
2. Owing to the size and weight of the loveseat, we recommend that it is assembled by two adults, on a carpeted or padded area, in the room that it is intended for. Approximate assembly time: 30 minutes.
3. Please do not use any tools other than those provided or recommended in these instructions.
4. Please do not throw away any of the packaging or the instruction until you have checked all the components and hardware and the furniture is fully assembled. Please ensure that the packaging is disposed of in a safe and environmentally friendly way.
5. Assemble all components loosely until advised to tighten. Depending on use, it may be necessary to tighten the components from time to time, so please save the tools that have been provided.
6. Please keep all pieces out of reach of children.



### Hardware:

- A.  Bolt M6x20mm x4
- B.  Bolt M6x25mm x6
- C.  Allen Wrench x1

### Components:

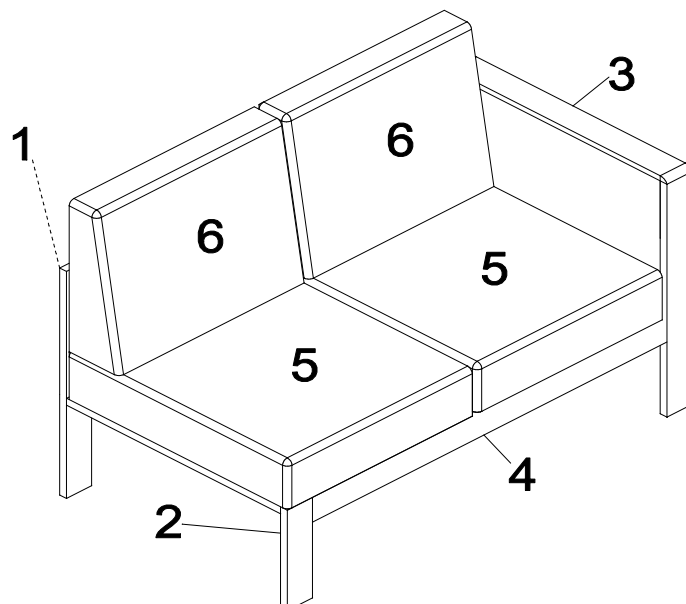

1. Top Rail	x1	2. Left Leg	x1	3. Right Leg	x1
4. Seat Frame	x1	5. Seat Cushion	x2	6. Back Cushion	x2

**STEP 1:**

1. Remove the plastic covers which pre-install at the end of the **Seat Frame (4)** by using **Allen Wrench (C)**.
2. Please put the **Right Leg (3)** on a carpeted or padded area as shown.
3. Insert the **Top Rail (1)** into the **Right Leg (3)** as shown.
4. Insert the **Seat Frame (4)** into the **Right Leg (3)** as shown with **Figure**.  
**Note: The bottom of the Seat Frame (4) and the Right Leg (3) is marked with Front. Abt. 3cm from the top of the seat to the top of seat back rail and 1.5cm for the seat front.**
5. Insert 3 pieces of **Bolts (B)** from the pre-drilled holes on the bottom of the **Top Rail (1)** and the **Seat Frame (4)** into each side on the bottom of the **Right Leg (3)**.
6. Insert 2 pieces of **Bolts (A)** from the pre-drilled holes on the side rail of the **Seat Frame (4)** into each end of **Right Leg (3)** as shown. Do not fully tighten **Bolts (A&B)** at this step.
7. Repeat the same steps for the **Left Leg (2)**.
8. After checking the leveling for all connections, please use **Allen Wrench (C)** to tighten all **Bolts (A&B)** clockwise until secure.

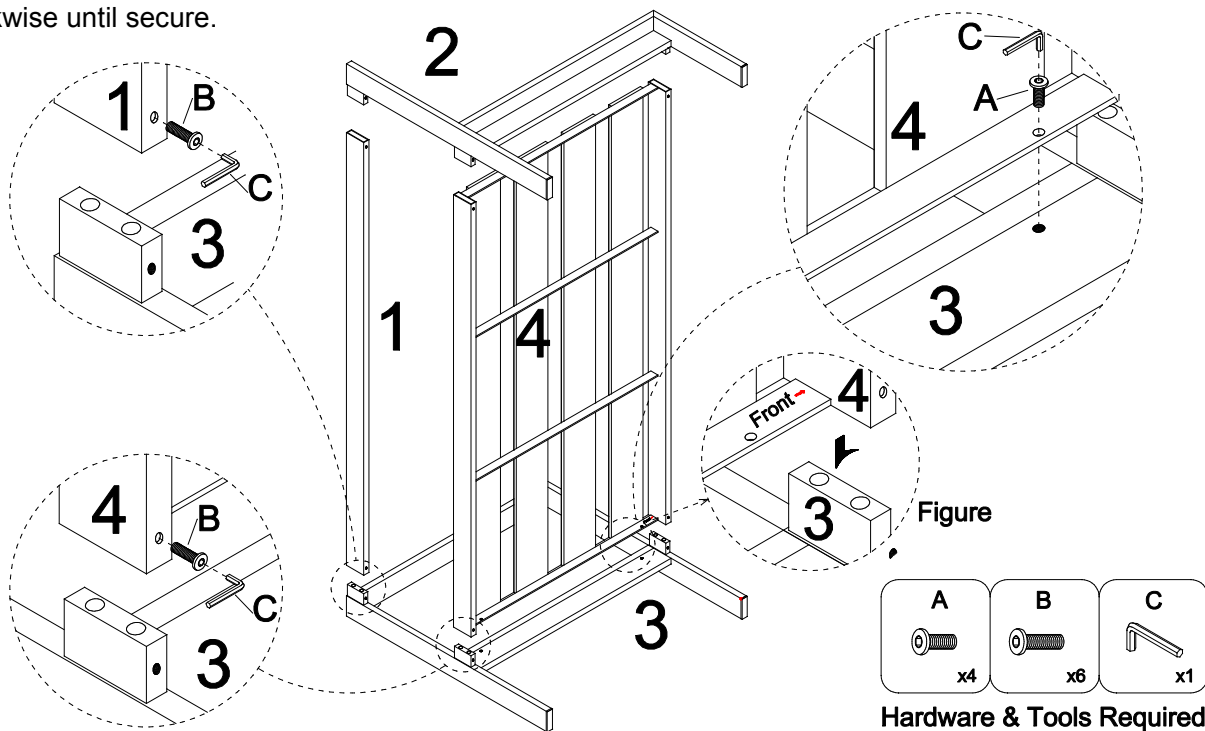

**STEP 2:**

1. Carefully place the assembled loveseat at your desired location.
2. Put the **Seat Cushions (5)** and **Back Cushions (6)** to assembled loveseat frame as shown.

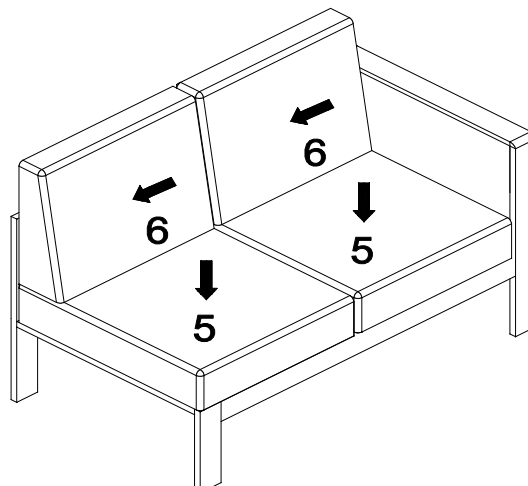

Assembly is complete. Your loveseat is ready to enjoy now!