

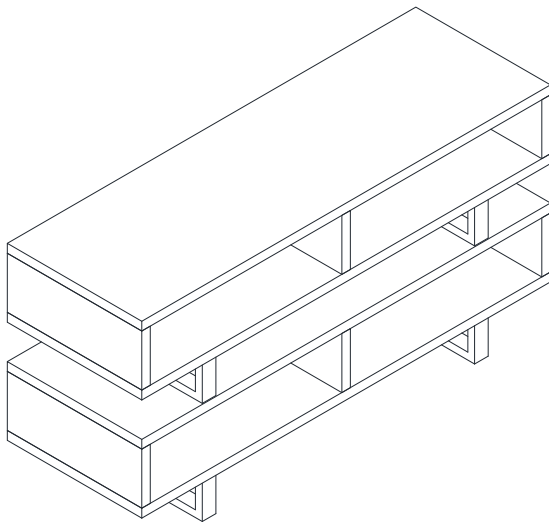









Thank you for purchasing the **MODWAY TV STAND**!

Before you start, here is some helpful advice:

1. We suggest you spend a short time reading through this leaflet and then follow the simple step-by-step instructions.
2. Owing to the size and weight of the TV stand, we recommend that it is assembled by two adults, on a carpeted or padded area, in the room that it is intended for. Approximate assembly time: 30 minutes.
3. Please do not use any tools other than those provided or recommended in these instructions.
4. Please do not throw away any of the packaging or the instruction until you have checked all the components and hardware and the furniture is fully assembled. Please ensure that the packaging is disposed of in a safe and environmentally friendly way.
5. Assemble all components loosely until advised to tighten. Depending on use, it may be necessary to tighten the components from time to time, so please save the tools that have been provided.
6. Please keep all fitting out of reach of children.



### Hardware:

A		Double-ended Bolt M8x190mm	x12
B		Dowel $\phi$ 8x40mm	x24
C		Nut M8	x12
D		Flat Washer M8	x24
E		Box Wrench #8	x1
F		Long Bolt M8x30mm	x8
G		Short Bolt M6x25mm	x4
H		Allen Wrench #5	x1
J		Mat 40x40mm	x4

### Components:

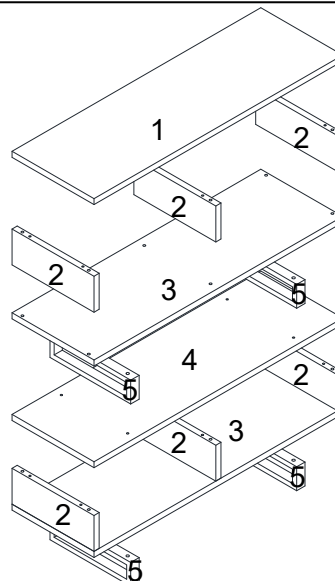

1	Top Panel	x1	2	Side Panel	x6	3	Bottom Panel	x2
	4	Center Panel	x1	5	Leg	x4		

## STEP 1:

Put **Top Panel (1)** upside down on a carpeted or padded area.

Insert 6 pieces of **Double-ended Bolt (A)** into the corresponding holes in the **Top Panel (1)** by hand as shown.

Tighten all the **Double-ended Bolts (A)** clockwise until secure.

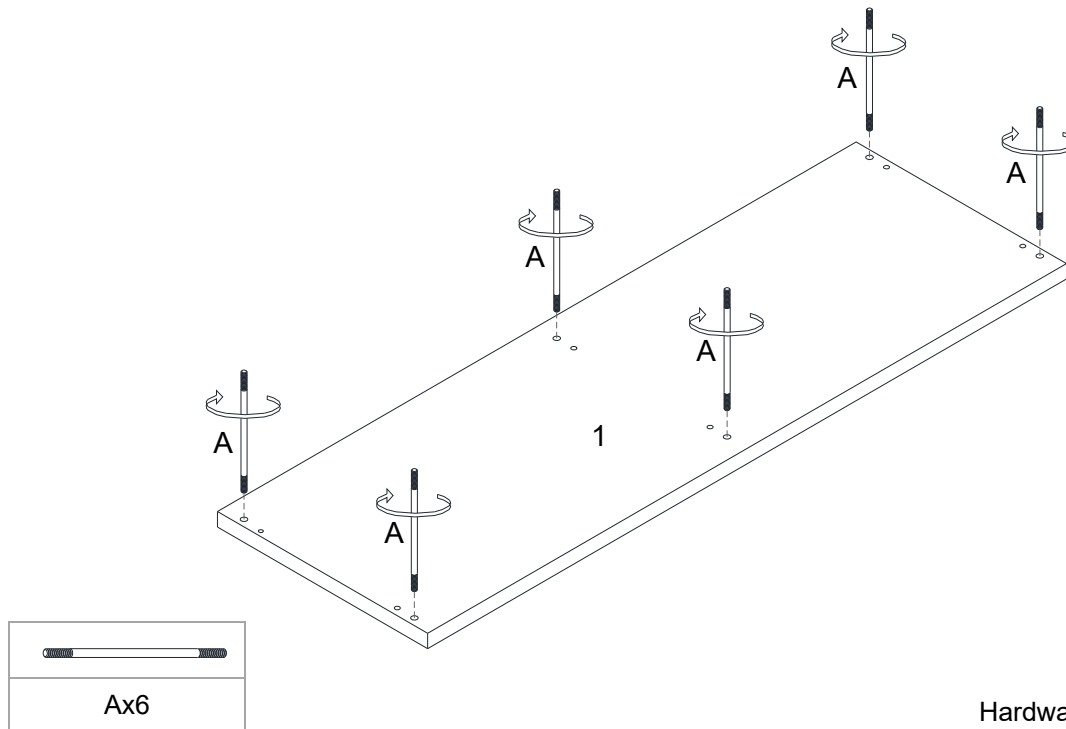

Hardware & Tool required

## STEP 2:

Insert 4 pieces of **Dowel (B)** into 4 holes of **Side Panel (2)** as shown.

Repeat the same steps for the remaining 5 pieces of **Side Panel (2)**.

Position 3 pieces of assembled **Side Panel (2)** to **Top Panel (1)** as shown.

Please confirm the assembled **Double-ended Bolts (A)** and **Dowel (B)** have been inserted into the pre-drilled holes in **Top Panel (1)** fully as shown.

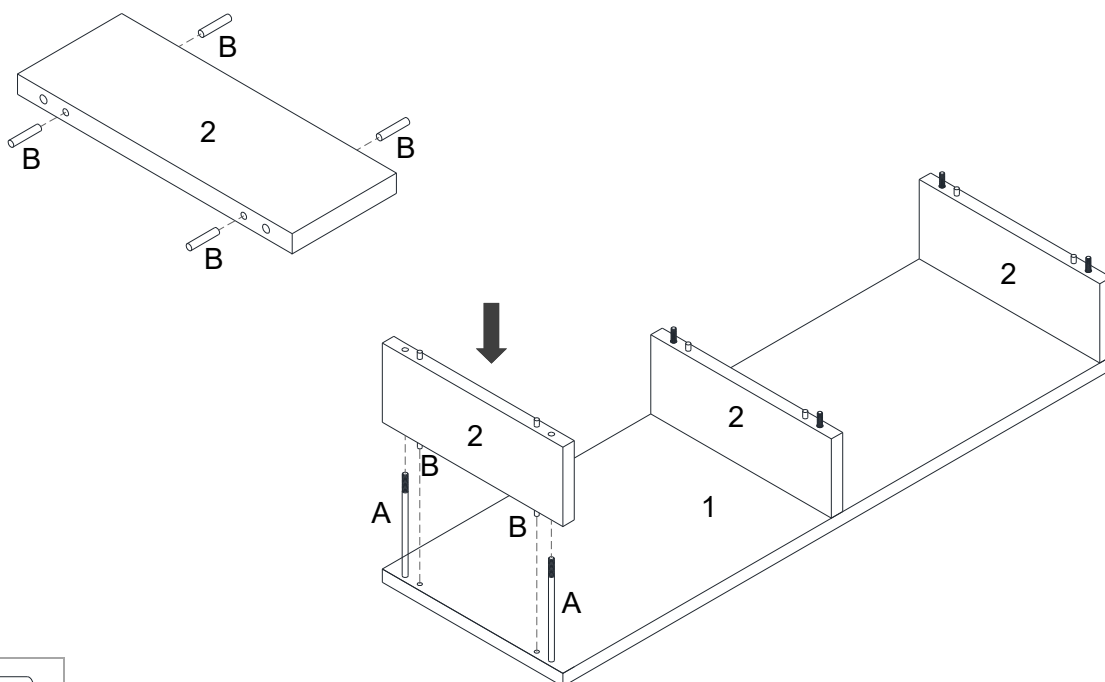

Hardware & Tool required

### STEP 3:

Put **Bottom Panels (3)** upside down on a carpeted or padded area.

Position 1 piece of **Bottom Panel (3)** to the assembled **Top panel (1)** and **Side Panels (2)** as shown.

Please confirm the assembled **Double-ended Bolts (A)** and **Dowels (B)** have been inserted into the pre-drilled holes on **Bottom Panel (3)** fully.

Insert 6 pieces of **Nut (C)** with 6 pieces of **Flat Washer (D)** into the assembled **Double-ended Bolts (A)** as shown.

Use **Box Wrench (E)** to tighten all the **Nuts (C)** clockwise until secure.

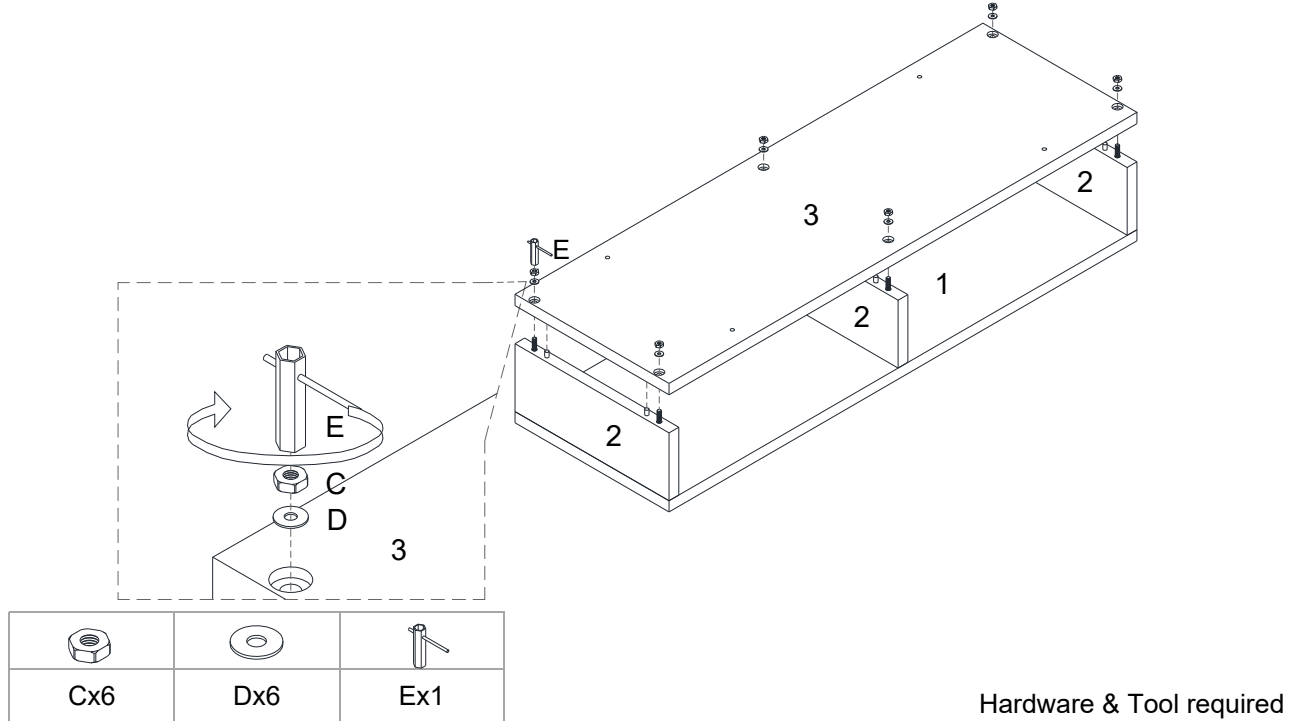

### STEP 4:

Position 1 piece of **Legs (5)** to the assembled **Top Panel (1)**, **Side Panels (2)**, and **Bottom Panel (3)** as shown.

Insert 2 pieces of **Long Bolt (F)** with 2 pieces of **Flat Washer (D)** into the pre-drilled holes in the **Bottom Panel (3)** through the holes in the **Leg (5)**.

Use **Allen Wrench (H)** to tighten **Long Bolts (F)** clockwise until secure.

Repeat the same steps for the other piece of **Leg (5)**.

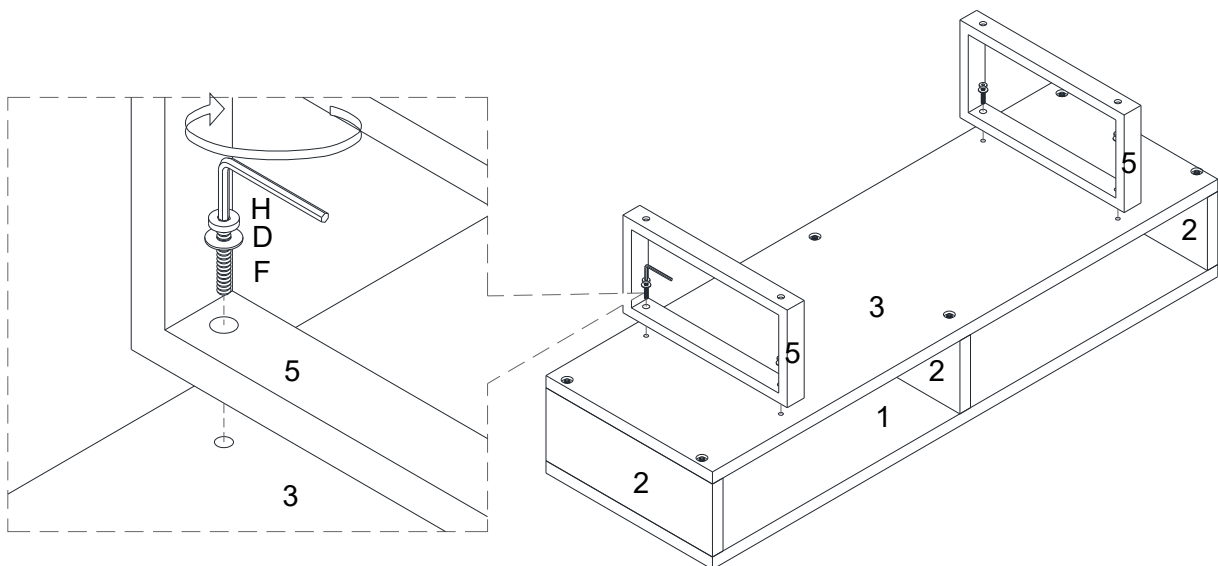

Dx4	Fx4	Hx1

Hardware & Tool required

**STEP 5:**





Position **Center Panel (4)** to the assembled **Top Panel (1)**, **Side Panels (2)**, **Bottom Panel (3)**, and **Legs (5)** as shown. Insert 4 pieces of **Short Bolts (G)** with 4 pieces of **Flat Washer (D)** into the pre-drilled holes in the **Legs (5)** through the holes in the **Center Panel (4)**.

Use **Allen Wrench (H)** to tighten **Short Bolts (G)** clockwise until secure.

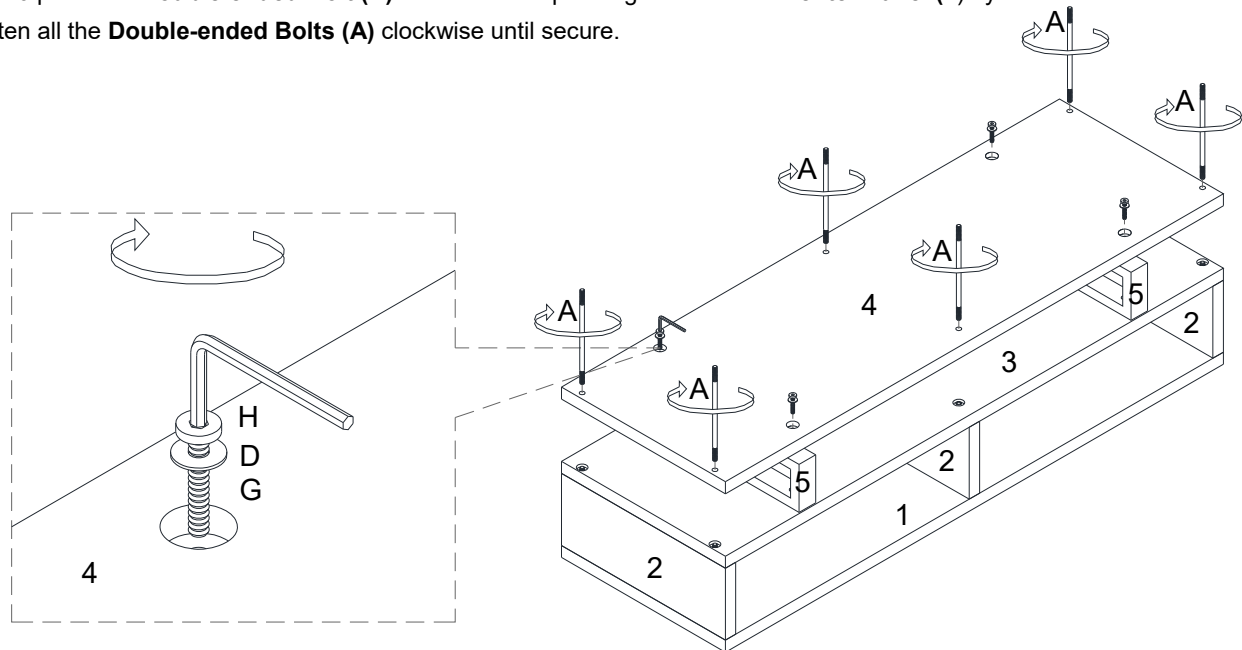
Insert 6 pieces of **Double-ended Bolt (A)** into the corresponding holes on the **Center Panel (4)** by hand as shown.

Tighten all the **Double-ended Bolts (A)** clockwise until secure.



			
Ax1	Dx4	Gx4	Hx1

Hardware & Tool required

**STEP 6:**

Position the remaining 3 pieces of assembled **Side Panel (2)** to the assembled **Top Panel (1)**, **Side Panels (2)**, **Bottom Panel (3)**, and **Center Panel (4)** as shown.

Please confirm the assembled **Double-ended Bolts (A)** and **Dowel (B)** have been inserted into the pre-drilled holes on **Center Panel (4)** fully as shown.

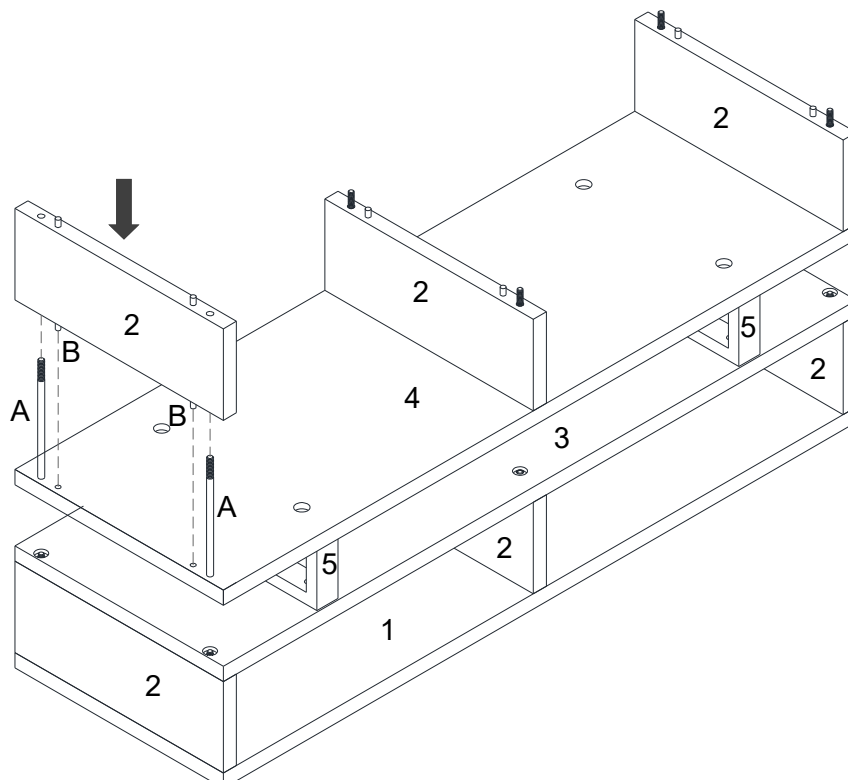

## STEP 7:

Position the other piece of **Bottom Panel (3)** to the assembled **Top Panel (1)**, **Side Panels (2)**, **Bottom Panel (3)**, and **Center Panel (4)** as shown.

Please confirm the assembled **Double-ended Bolts (A)** and **Dowel (B)** have been inserted into the pre-drilled holes on the other piece of **Bottom Panel (3)** fully.

Insert 6 pieces of **Nut (C)** with 6 pieces of **Flat Washer (D)** into the assembled **Double-ended Bolts (A)** as shown.

Use **Box Wrench (E)** to tighten all the **Nuts (C)** clockwise until secure.

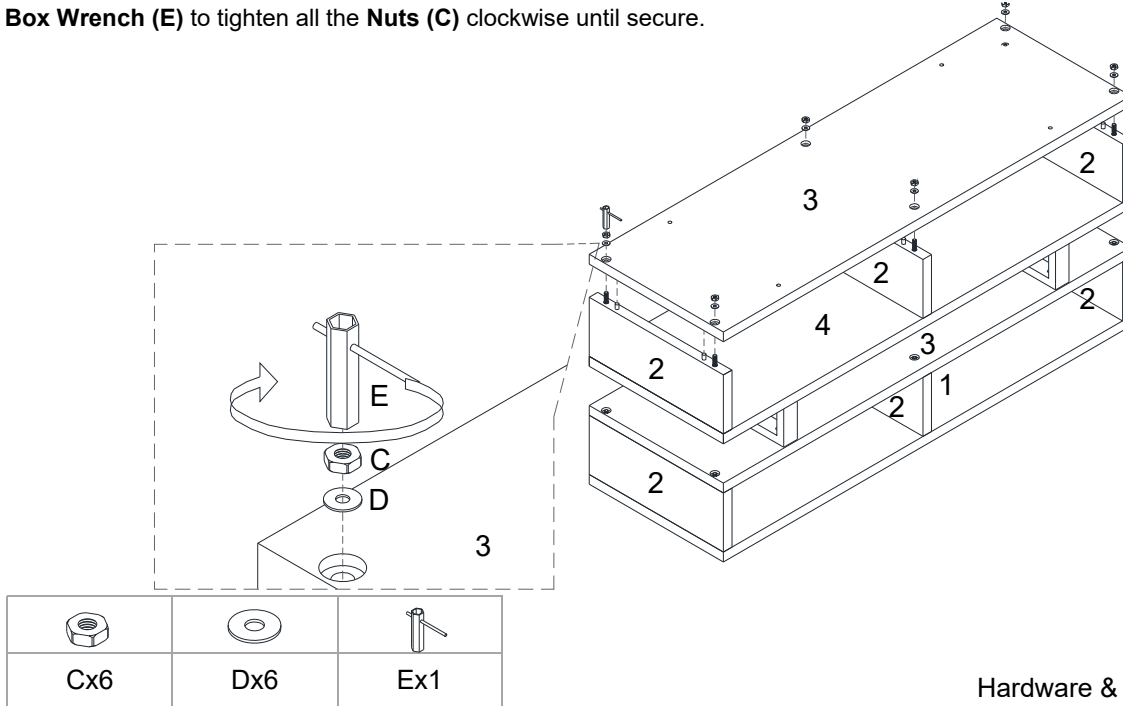

Hardware & Tool required

## STEP 8:

Position 1 piece of **Legs (5)** to the assembled **Top Panel (1)**, **Side Panels (2)**, and **Bottom Panel (3)** as shown.

Insert 2 pieces of **Long Bolts (F)** with 2 pieces of **Flat Washer (D)** into the pre-drilled holes in the **Bottom Panel (3)** through the holes in the **Leg (5)**.

Use **Allen Wrench (H)** to tighten **Long Bolts (F)** clockwise until secure.

Repeat the same steps for the other piece of **Leg (5)**.

Tear off the sticker on the 4 pieces of **Mats (J)**.

Carefully attach 4 pieces of **Mat (J)** to **Legs (5)** as shown.

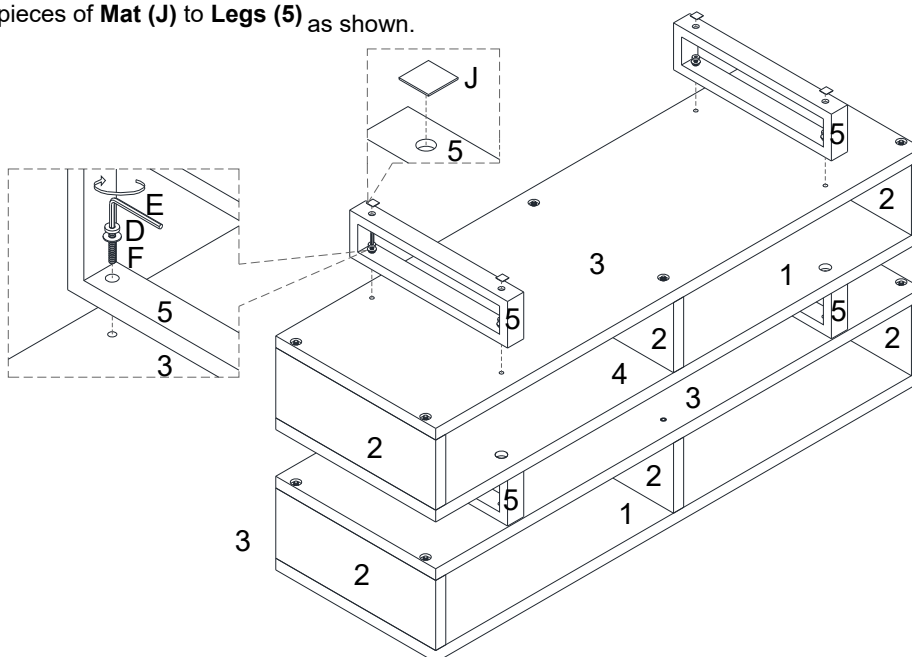

Dx4	Fx4	Hx1	Jx4

Hardware & Tool required

**STEP 9:**

Carefully turn over the assembled TV stand.

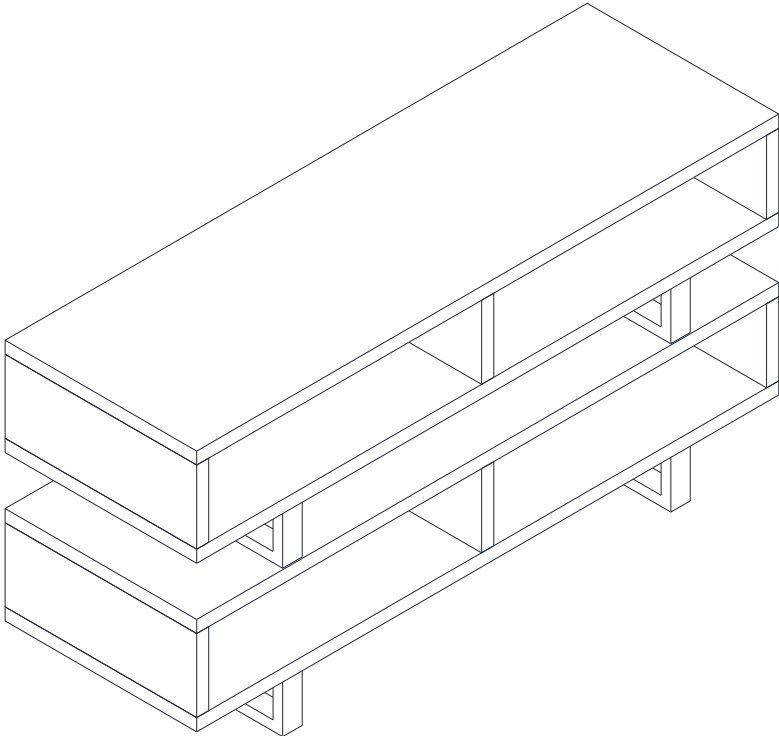

Assembly is complete. Your TV stand is ready to be used now!