

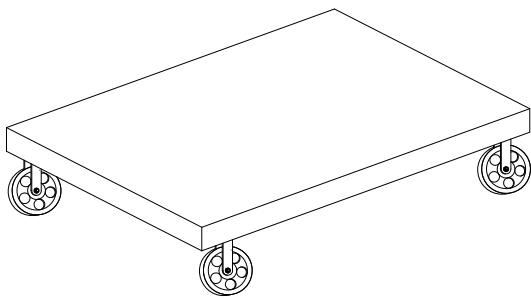



Thank you for purchasing the **GARRISON COFFEE TABLE!**

Before you start, here is some helpful advice:

1. We suggest you spend a short time reading through this leaflet and then follow the simple step by step instructions.
2. Approximate assembly time: 15 minutes.
3. Please do not use any tools other than those provided or recommended in these instructions.
4. Please do not throw away any of the packaging or instructions until you have checked all the components and hardware and the furniture is fully assembled.
5. Assemble all components loosely until advised to tighten. Depending on use, it may be necessary to tighten the components from time to time, so please save the tools that have been provided.
6. Please keep all pieces out of reach of small children.



Hardware:

A		Bolt 8x20mm	x16
B		Flat Washer	x16
C		Allen Wrench	x1

Component:

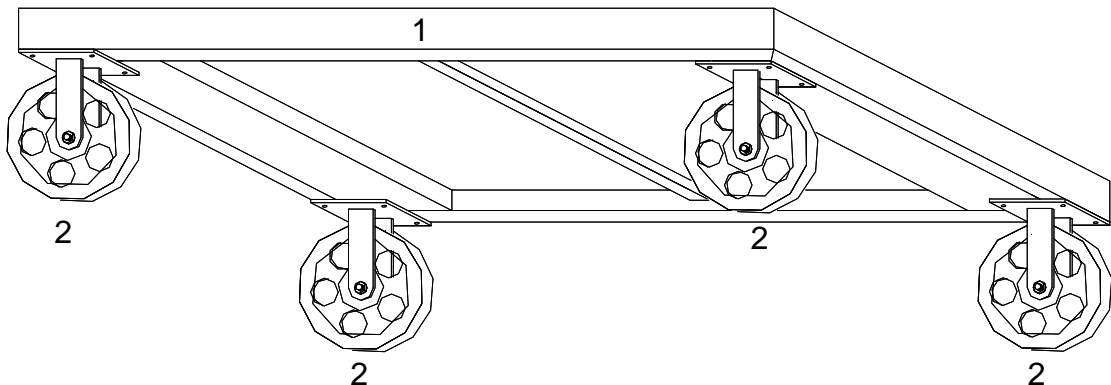

1 Top x1

2 Castor x4

STEP 1:



Please put the **Top (1)** upside down on a carpeted or padded surface.

Attach one **Castor (2)** into the bottom of **Top (1)** by using **Bolts (A)** and **Flat Washers (B)** as shown.

Use the **Allen Wrench (C)** to tighten the **Bolts (A)** clockwise until secure.

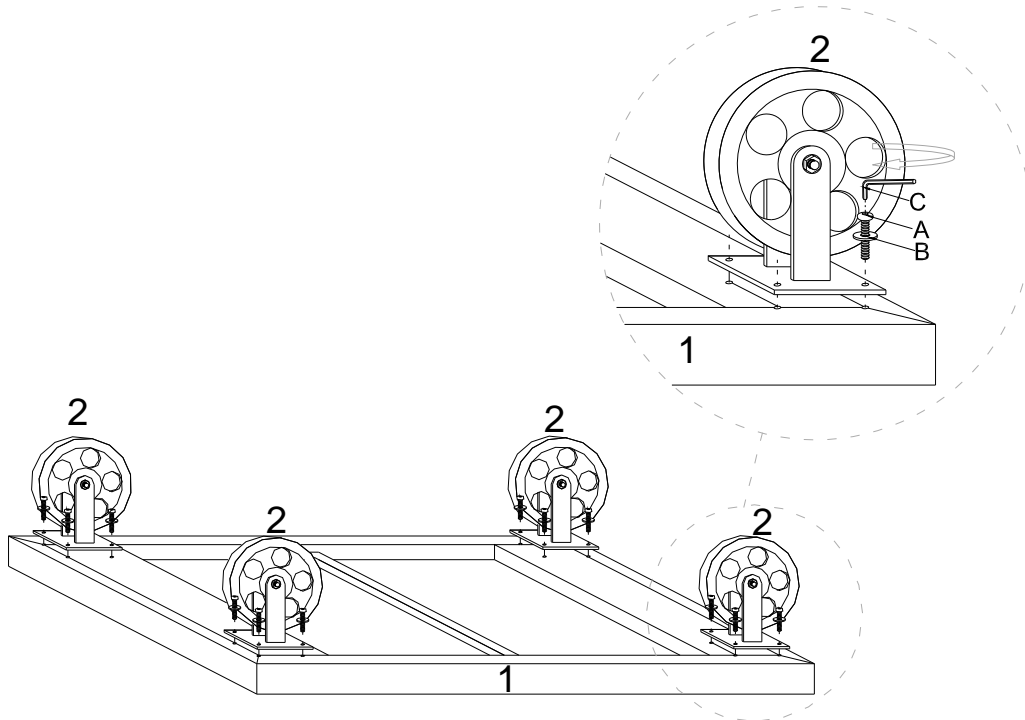
Repeat the same steps for the other three **Castors (2)**.



		
Ax16	Bx16	Cx1

Hardware & Tool required

STEP 2:

Carefully turn over the coffee table.

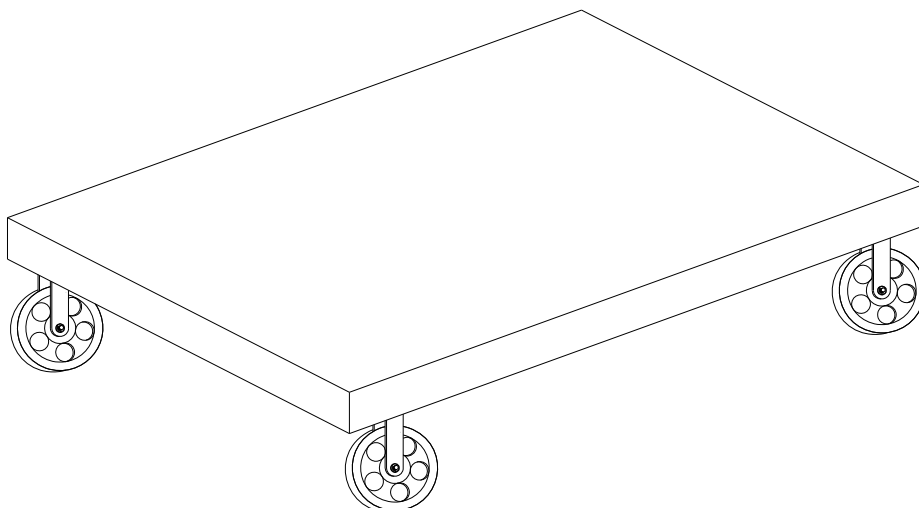

Assembly is completed. The coffee table is ready to enjoy now!